

# AUTOMATIC FEM APPROACHES TO CONNECTIONS DESIGN

## Sw Connection Study Environment

From a lecture at the Order of Engineers, Milan, June, 19, 2014

Ing. Paolo Rugarli

Castalia srl – Milan – Italy

[www.castaliaweb.com](http://www.castaliaweb.com) – [www.steelchecks.com](http://www.steelchecks.com)

paolo.rugarli@castaliaweb.com



**CASTALIA**

# Connections

- This is a quite complex field.
- It has been over simplified due to its high complexity.
- Many structural failures are due to improper connection design.
- I dare say this is today the less enhanced field of structural analysis.
- People want *cooking recipes*, but they use them far beyond their limits of applicability.
- Connection design is seen as a poor activity.
- Enormous money savings can be got by a more advanced connection design.

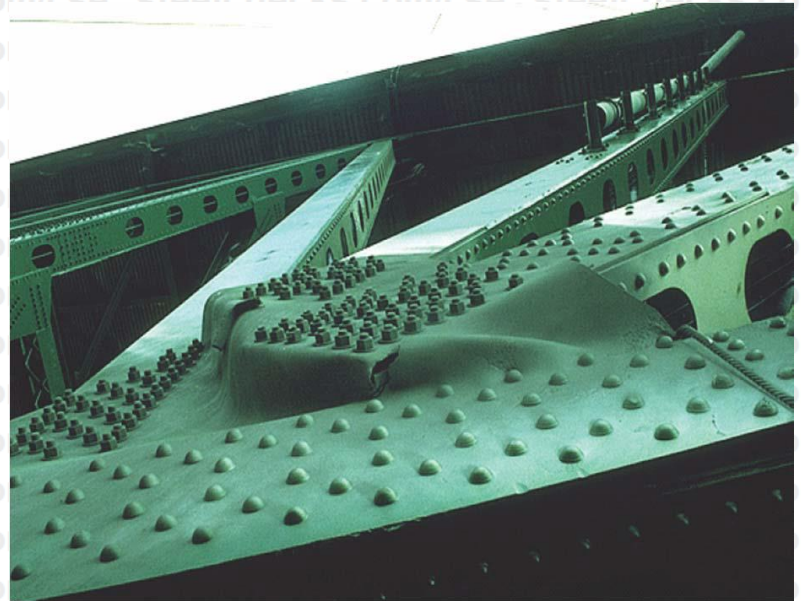

Bridge gusset plate buckling failure.

FINITE ELEMENT SIMULATION AND ASSESSMENT OF THE STRENGTH  
BEHAVIOR OF RIVETED AND BOLTED GUSSET-PLATE CONNECTIONS IN  
STEEL TRUSS BRIDGES  
FINAL REPORT

Georgia Southern University, Statesboro, GA, March 2013

# Some preliminary considerations

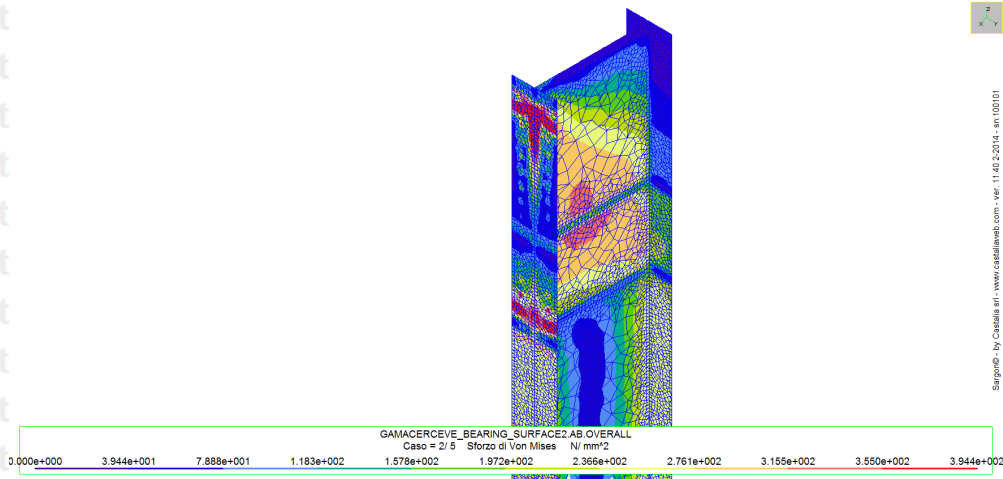

- This work started in 1999, with the aim to fully cover connection design, i.e. to find a **general approach** (also to welded connections).
- During these years I have worked at this problem alone, so **this is a personal view**. I do not agree with currently used approaches and I felt free to search for a different path.
- However, there is an increasing number of colleagues, in several Countries all around the world, agreeing that the **automatic FEM approach** is the future of connection design
- I am one of them.
- Research is not finished. Several aspects have to be improved. However, automatic fem modeling and checking of connections is already available.

# Acknowledgements

- Research funds got by Italian Agencies: 0€
- Cooperation with Italian University: none
- European funds for innovative research: 0€
- But... this research has been made in Italy, at Milan



Bramante's  
S. Maria delle Grazie  
Milan, Italy (1492-1497)



# Why FEM?

- NOT to be “precise”. In connection design “preciseness” just does not exist (friction, gaps, lack of planarity, prying forces, plasticity, geometric effects, imperfections...).
- NOT to have 4 significant digits results, then.
- NOT to waste time
- NOT to have useless complexity
- NOT to stay hours waiting for results

# Why FEM ? (2)

- Because FEM is general.
- Because FEM can be automated.
- Because a Von Mises stress map... speaks
- Because many errors are due to neglecting important forces components.
- Because many errors are due to improper additional moment computations
- Because traditional means are too coarse.
- Because connection design is still a bottle-neck

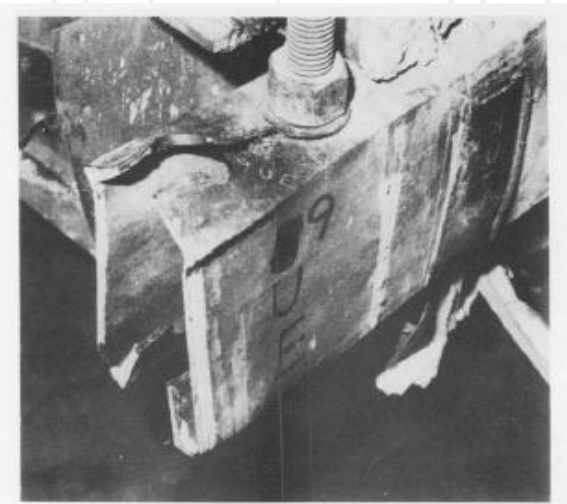

# The problem

- Given a generic “scene” like this....

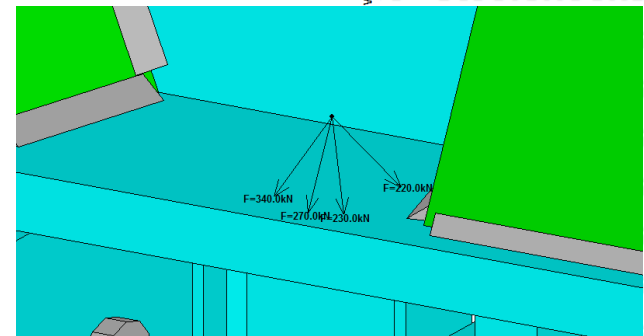
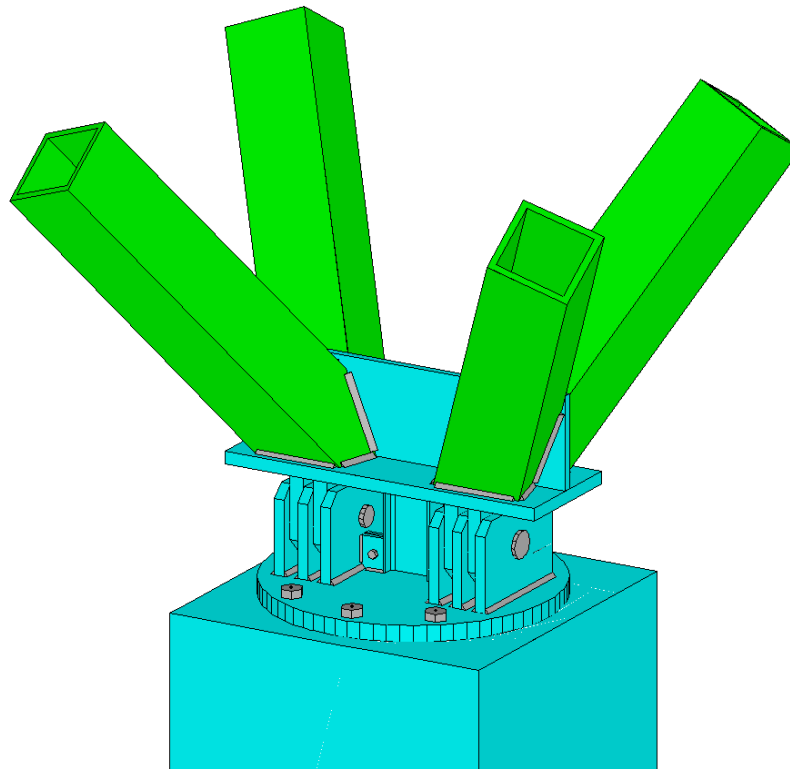
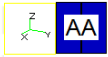

Courtesy: Ing. Alborghetti – Rovato (Italy)

# Or these...

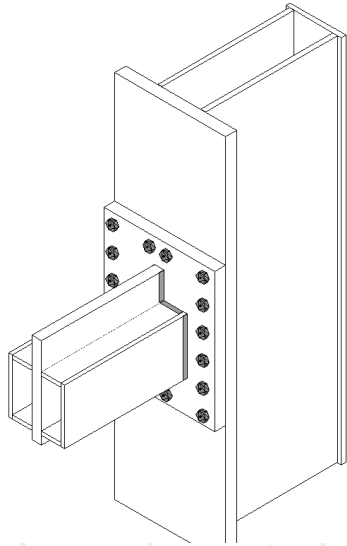

Courtesy: CEN, Bochum, Germany

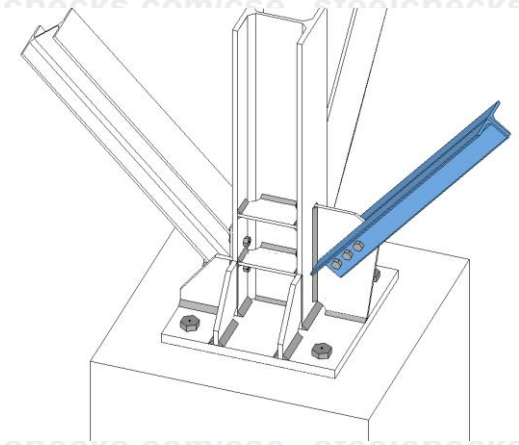
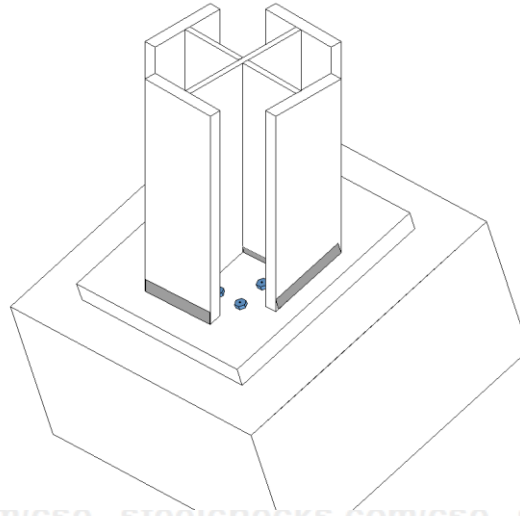

Courtesy SZF (Italy)

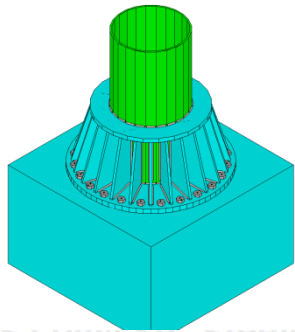

Courtesy: Ing. Bagnasco (Italy)

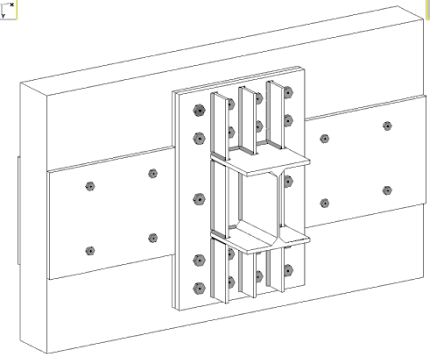
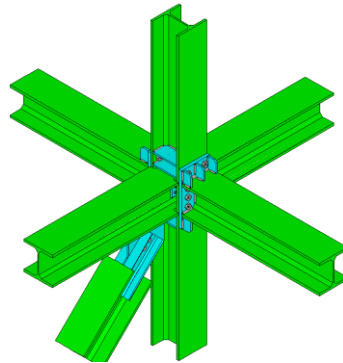

Courtesy: ing. Galluzzi (Florence – Italy)

# Or again like these...

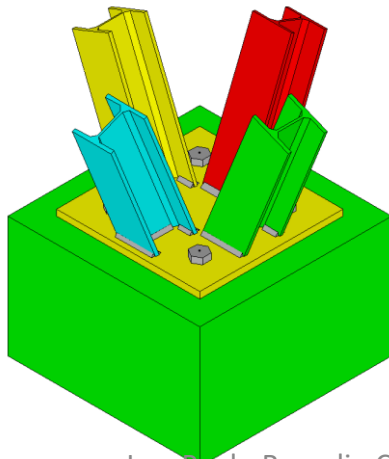
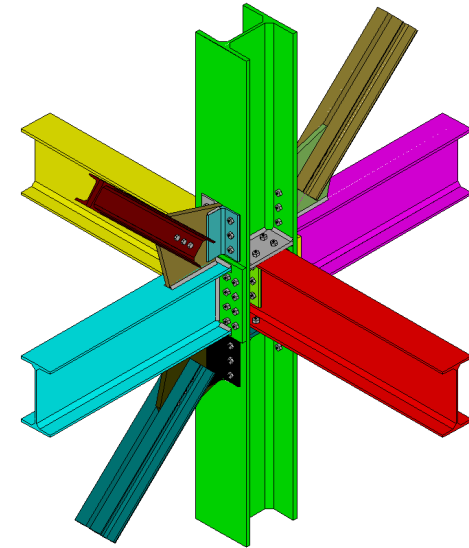
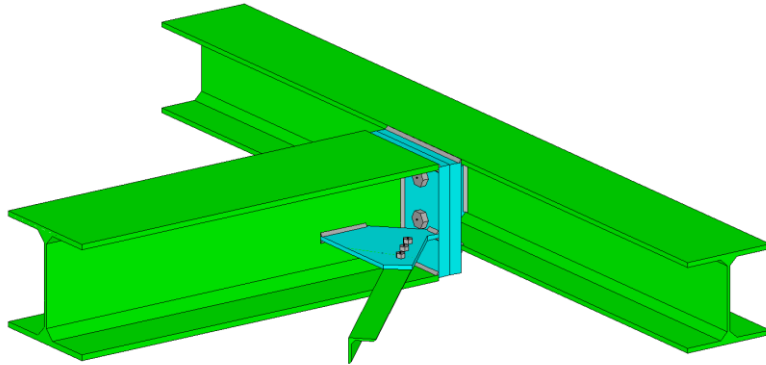

And assumed known the internal forces at the extremities of the fem elements defining the members, or at the extremities of the members (as 3d objects) connecting at the node.....

We would like to **automatically** find....

- 1.The forces flowing in each component.
- 2.If the **joiners** are able to transfer those forces.
- 3.If these forces are below or above the “limit” of the **components** (keeping into account: resistance, stability and fatigue issues).
- 4.A reasonable amount for the displacements.
- 5.A reasonable estimate for the stiffnesses.

“Reasonable” means: SOUND from an ENGINEERING VIEW POINT

# How setting forces at extremities (1)

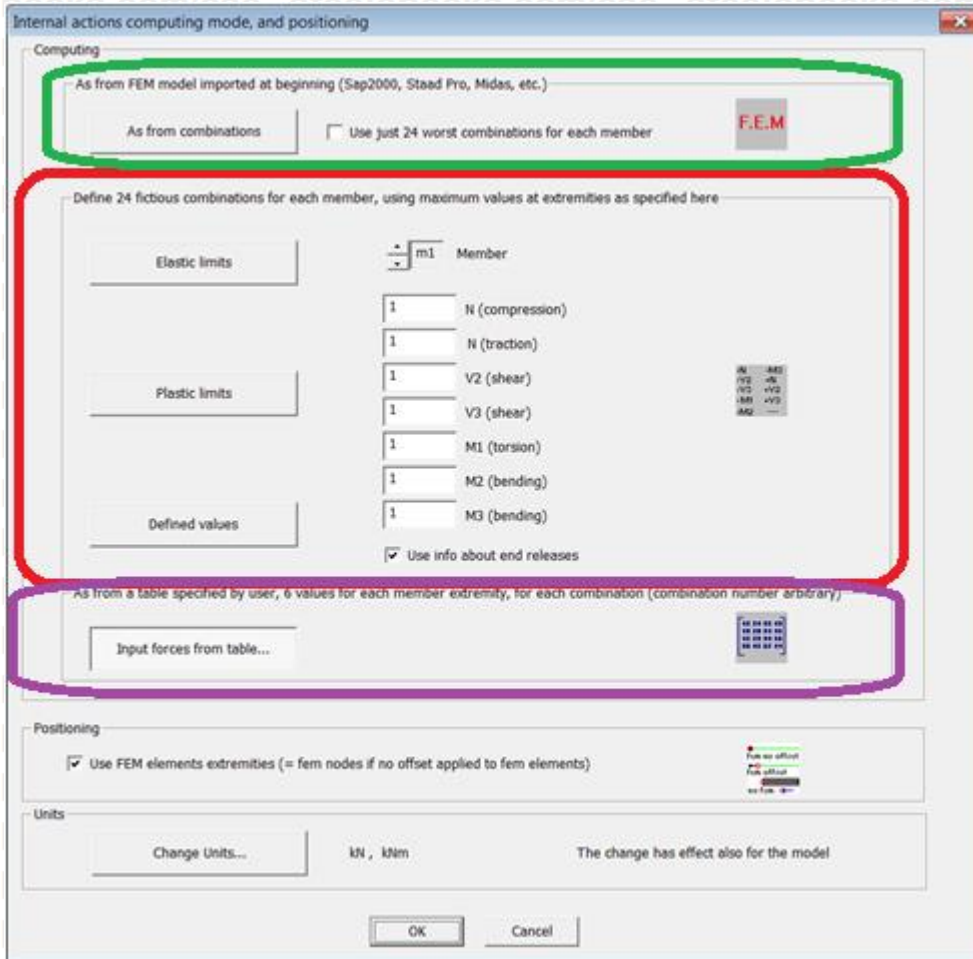

From BFEM (possibly “squeezed” to 24 worst combi/member)  
BFEM=standard fem model for design, “Bernoulli” FEM

Notionally, using (fraction of) elastic limits or plastic limits (overstrength), or “defined” values

Pasting a table of data

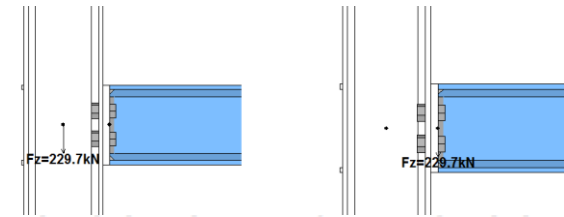

# How setting forces at extremities (2)

Internal actions input

Combi	Member	N (tab)	V2 (tab)	V3 (tab)	M1 (tab)	M2 (tab)	M3 (newline)
1	1	0.000e+000	0.000e+000	0.000e+000	0.000e+000	0.000e+000	0.000e+000
1	2	1.320e+002	1.650e+001	0.000e+000	0.000e+000	0.000e+000	0.000e+000
1	3	0.000e+000	0.000e+000	0.000e+000	0.000e+000	0.000e+000	0.000e+000
1	4	0.000e+000	0.000e+000	0.000e+000	0.000e+000	0.000e+000	0.000e+000
2	1	0.000e+000	0.000e+000	0.000e+000	0.000e+000	0.000e+000	0.000e+000
2	2	1.485e+002	1.925e+001	0.000e+000	0.000e+000	0.000e+000	0.000e+000
2	3	0.000e+000	0.000e+000	0.000e+000	0.000e+000	0.000e+000	0.000e+000
2	4	0.000e+000	0.000e+000	0.000e+000	0.000e+000	0.000e+000	0.000e+000
3	1	0.000e+000	0.000e+000	0.000e+000	0.000e+000	0.000e+000	0.000e+000
3	2	1.155e+001	2.860e+001	0.000e+000	0.000e+000	0.000e+000	0.000e+000
3	3	0.000e+000	0.000e+000	0.000e+000	0.000e+000	0.000e+000	0.000e+000
3	4	0.000e+000	0.000e+000	0.000e+000	0.000e+000	0.000e+000	0.000e+000
4	1	0.000e+000	0.000e+000	0.000e+000	0.000e+000	0.000e+000	0.000e+000
4	2	4.840e+001	1.870e+001	0.000e+000	0.000e+000	0.000e+000	0.000e+000
4	3	0.000e+000	0.000e+000	0.000e+000	0.000e+000	0.000e+000	0.000e+000
4	4	0.000e+000	0.000e+000	0.000e+000	0.000e+000	0.000e+000	0.000e+000
5	1	0.000e+000	0.000e+000	0.000e+000	0.000e+000	0.000e+000	0.000e+000
5	2	0.000e+000	0.000e+000	0.000e+000	0.000e+000	0.000e+000	0.000e+000
5	3	0.000e+000	0.000e+000	0.000e+000	0.000e+000	0.000e+000	0.000e+000
5	4	0.000e+000	0.000e+000	0.000e+000	0.000e+000	0.000e+000	0.000e+000

Clear Initialize, 5 combinations Units... kN, kNm Axis (1, 2, 3)... Paste from EXCEL or NOTEPAD If NOTEPAD then use tabs

OK Cancel

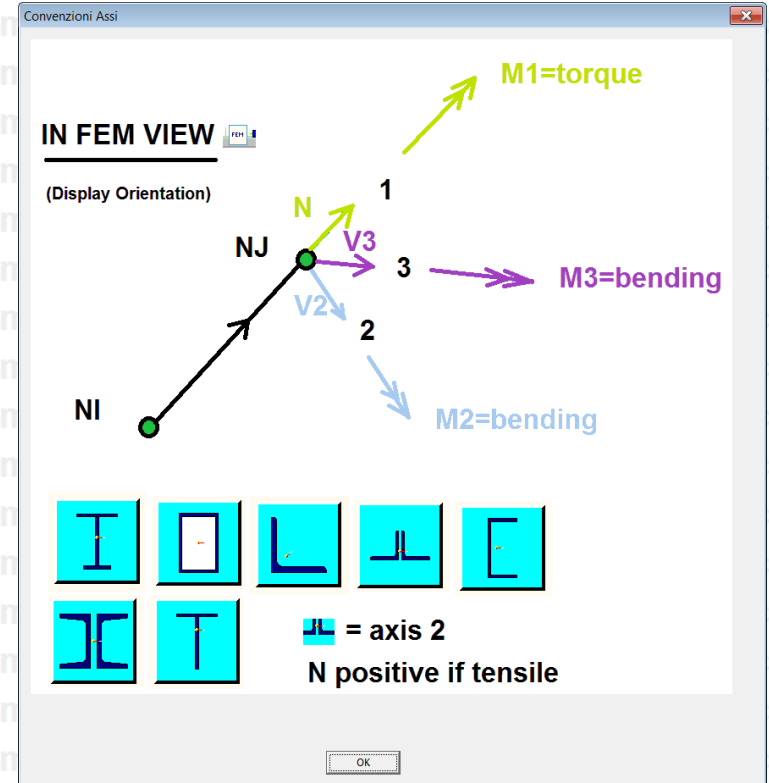

Direct setting of table values

And then....

# A flower opening....



Ing. Paolo Rugarli - Castalia srl - Milan - Italy  
- [www.castaliaweb.com](http://www.castaliaweb.com) -  
[www.steelchecks.com](http://www.steelchecks.com)

# A glance at the past....

Once upon a time, Engineers did compute structural layouts by means of graphical tools.

It was not even possible to imagine that a structure like this...

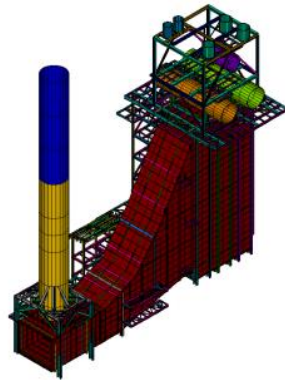

Courtesy: Walley Design – Olgiate Olona - VA

Could be checked by a fem model.

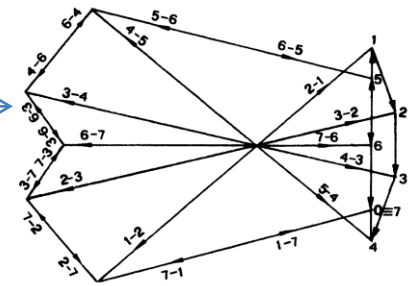
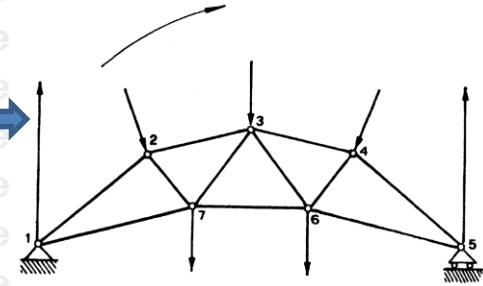

I AM NOT MEANING THAT  
THE ENGINEER IS NOT NEEDED

I MEAN  
WE NEED SKILLED ENGINEERS

So now when I say that a “node” like this...

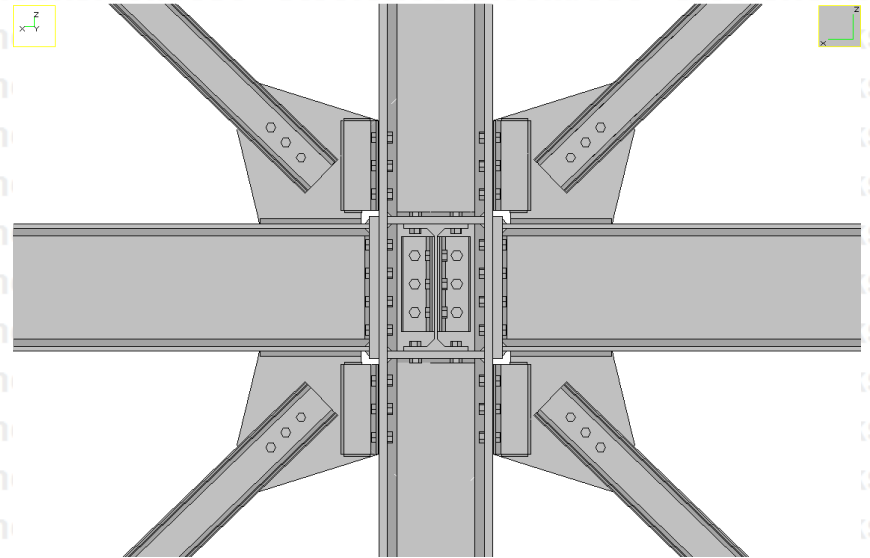
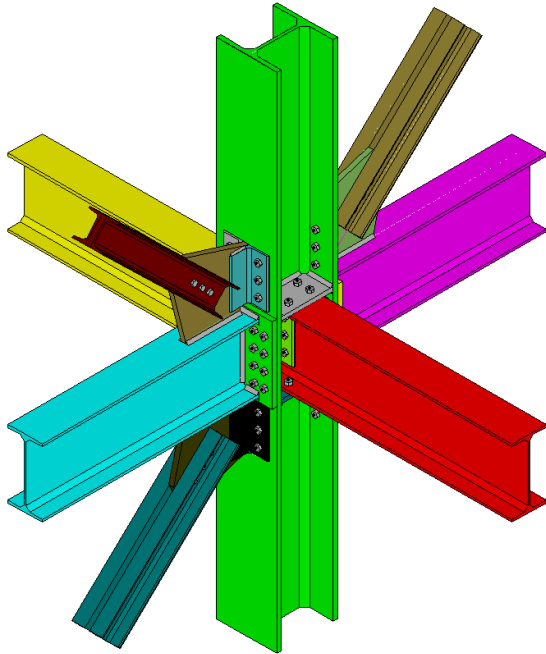

Can be computed automatically (by properly choosing pertinent options), some colleagues are surprised.

But, indeed, it can. YES WE CAN 😊

# We can solve every “scene” no matter how complex, irregular or crazy

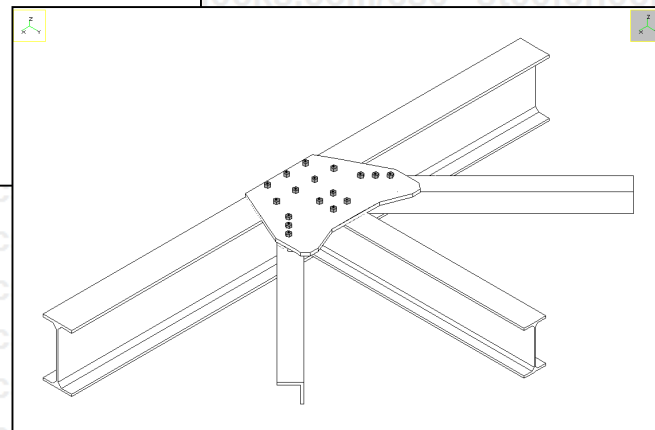
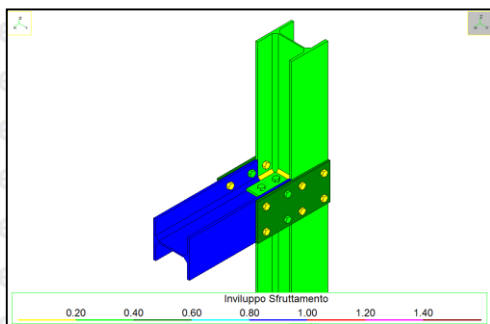
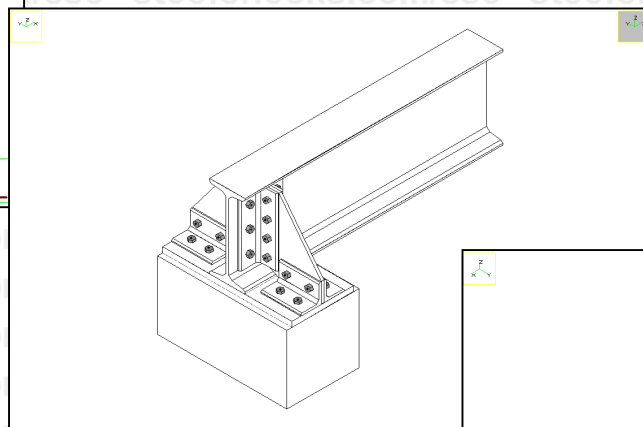
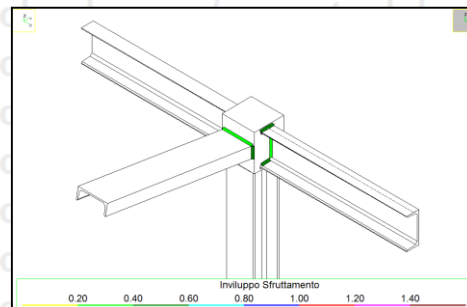
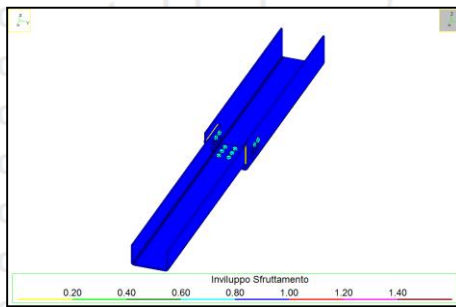
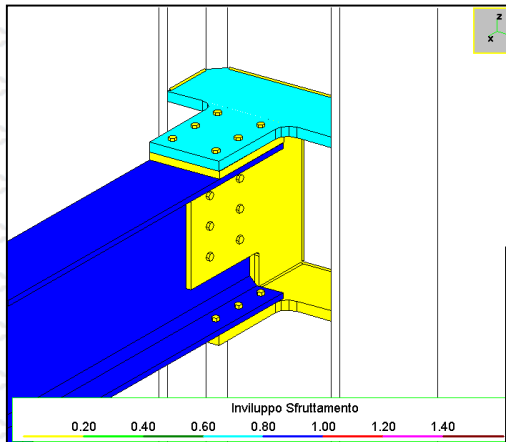

How can we do that?

The answer is...

Via FEM ANALYSES

When I started the work **I was not even thinking about FEM**. FEM turned out to be necessary after the problem had been analyzed in detail.

# Remember:

- NOT to be “precise”. In connection design “preciseness” just does not exist (friction, gaps, lack of planarity, prying forces, plasticity, geometric effects, imperfections...).
- NOT to have 4 significant digits results, then.
- NOT to waste time
- NOT to have useless complexity
- NOT to stay hours waiting for results

# Step 1

- A standard finite element model of a whole structure or just of the members meeting at a fem node, is created (BFEM).



Courtesy: Jean Nouvel Architects

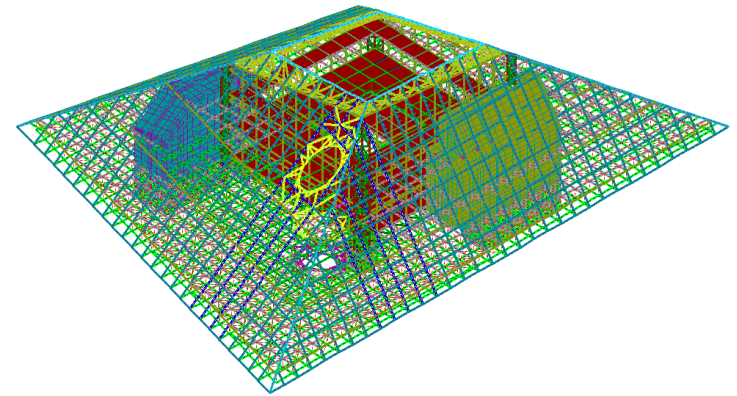

Courtesy: Studio Ing. Galluzzi, Florence

# Step 2

- Equal *jnodes* recognition

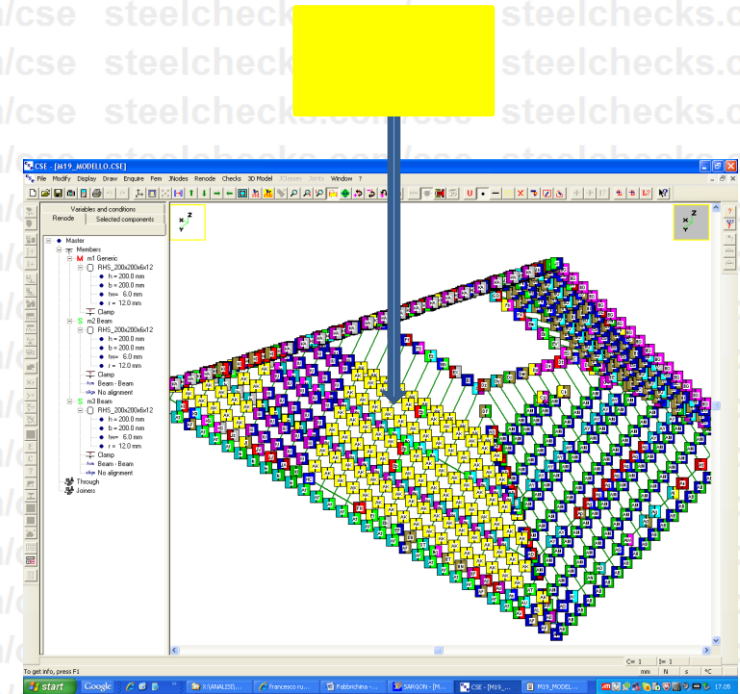
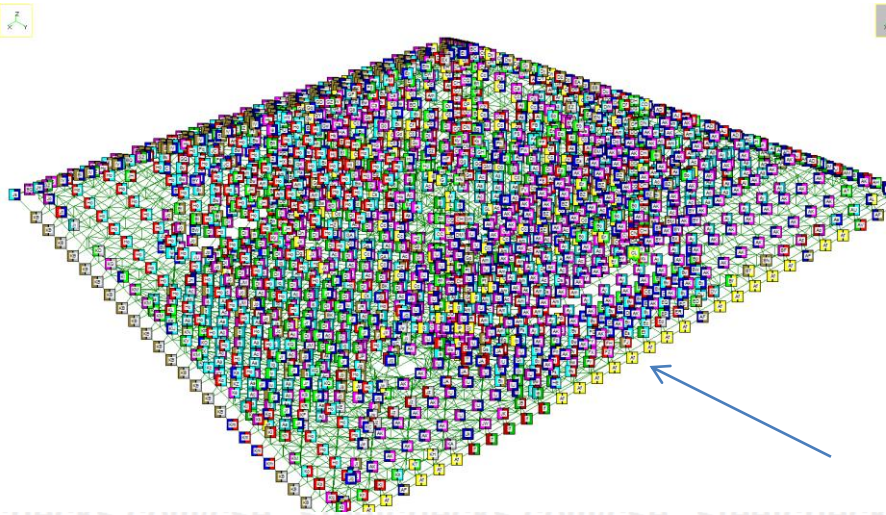

C.S.E.

**Node** : node in the fem model meaning

**Jnode**: wireframe information related to members meeting at a node (also **jclass**)

**Renode**: one way to construct jnode in 3D. Renode= scene + settings

**Prenode**: a parameterized real node

(this is a top complexity level example)

New necessary terminology, not a joke!

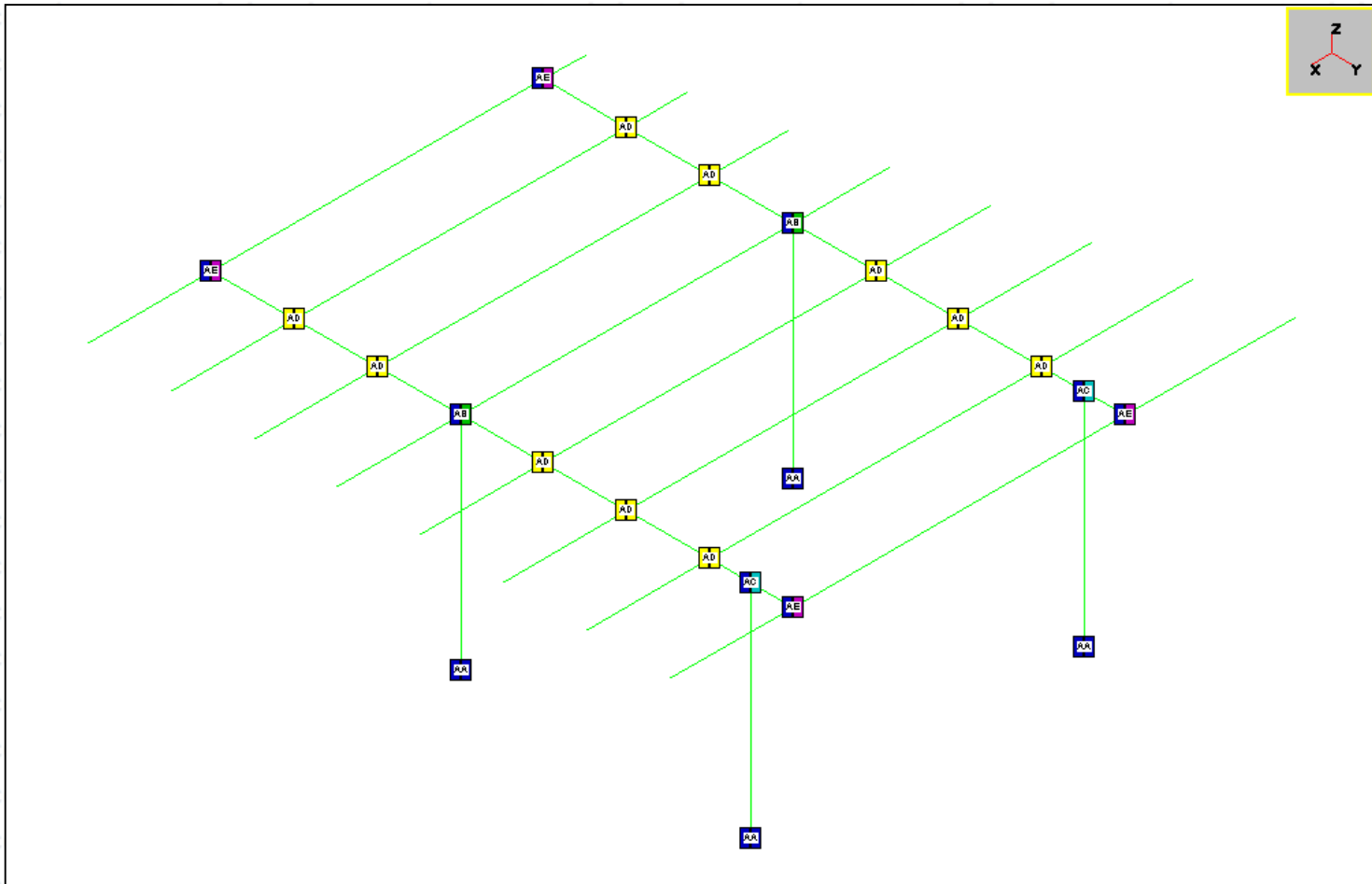

A much simpler case...

# JNODE ANALYTICS

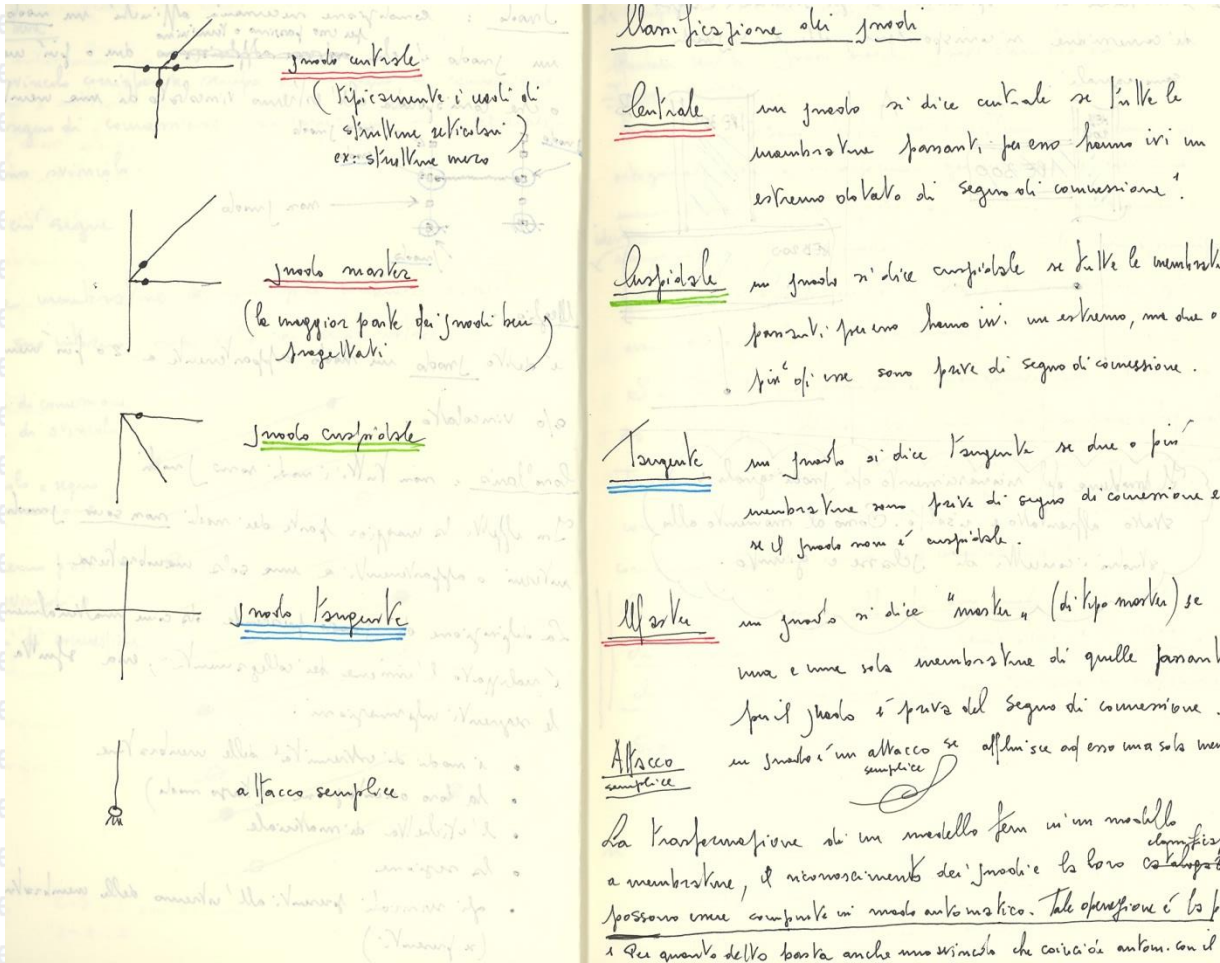



- Jnodes can be:
- Free
    - Central
    - Hierarchical
    - Cuspidal
    - Tangent
  - Constrained
    - Simple
    - Multiple (see above)
- Hierarchical = one "master", one or more "slaves" -> most part of jnodes

The "connection code" applied to beam elts allows automatic detecting...

# Step 3

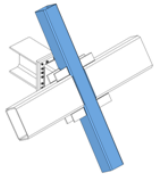
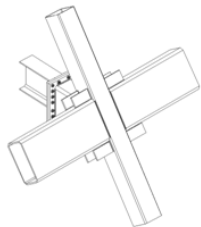
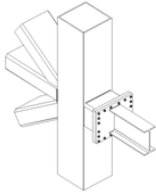
- Inode selection and construction of *Renode* (scene creation)

 <a href="http://www.castaliaweb.com">www.castaliaweb.com</a> - <a href="mailto:staff@castaliaweb.com">staff@castaliaweb.com</a>		
Iz $\alpha$		4-istanza]] Parete-solaio $\alpha$
Ay $\alpha$		22-istanza]] Parete-solaio $\alpha$
IR $\alpha$		1-istanza]] Vertice-torre-solaio-157 $\alpha$

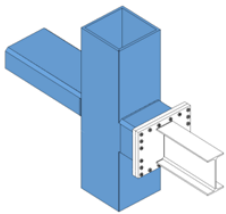
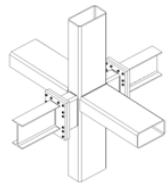
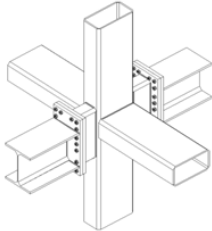
 <a href="http://www.castaliaweb.com">www.castaliaweb.com</a> - <a href="mailto:staff@castaliaweb.com">staff@castaliaweb.com</a>		
IQ $\alpha$		1-istanza]] Vertice-torre-solaio-154 $\alpha$
CY $\alpha$		18-istanza]] Torre-solaio-154 $\alpha$
Fy $\alpha$		5-istanza]] Torre-solaio-157 $\alpha$

Courtesy Ing. Galluzzi, Florence

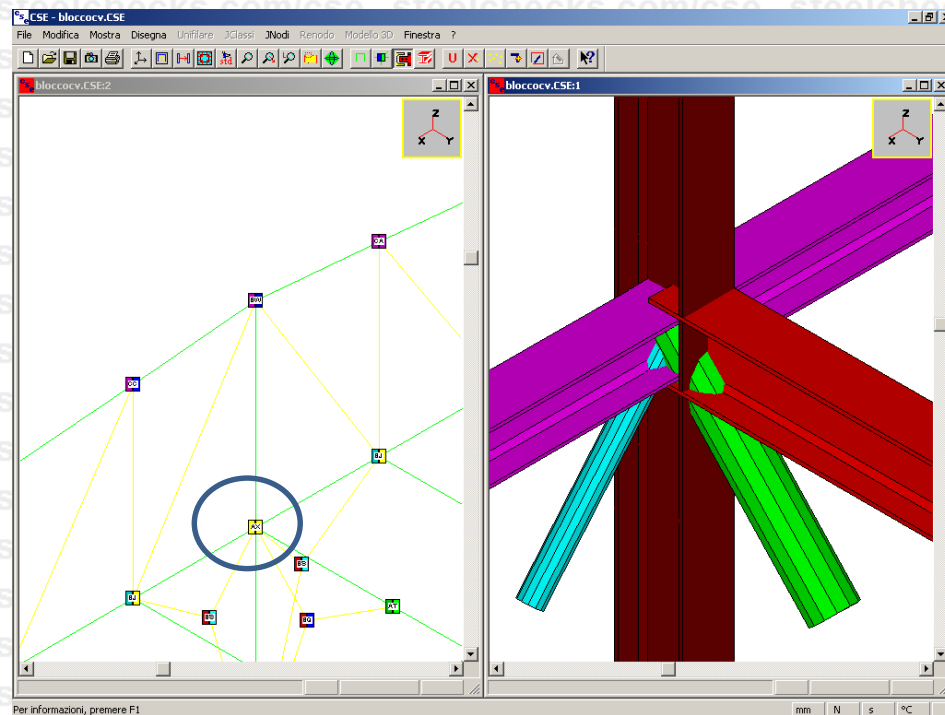

C.S.E.  
MDI interface

Initially members overlap.

- Scene creation prepared in such a way to automatically detect connections once proper geometrical rules are set up.
- These geometrical rules rely on surface contact, i.e. equal planes opposite normals recognition.
- The solids are modeled via (planar) B-REP, boundary representation.
- Once a component is B-REP defined it can receive “working process” and is no longer what initially was.

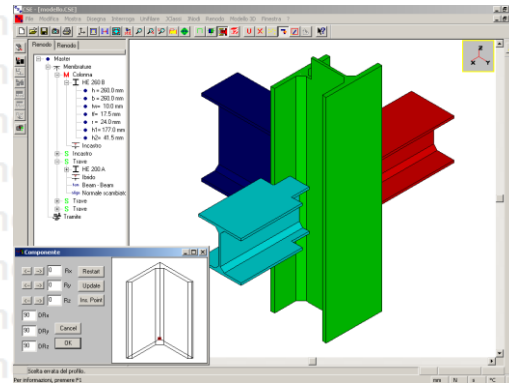

C.S.E.: adding a component

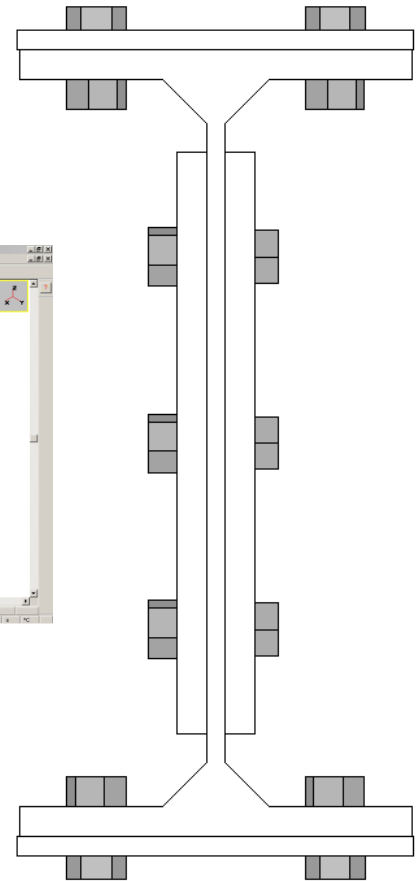

# Step 4

- Renode solution & checks

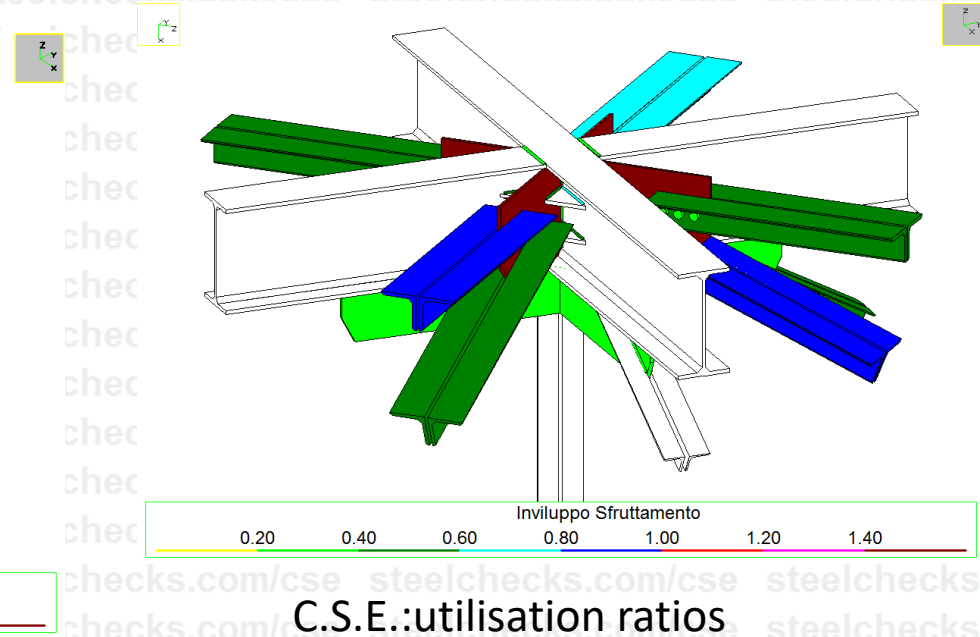
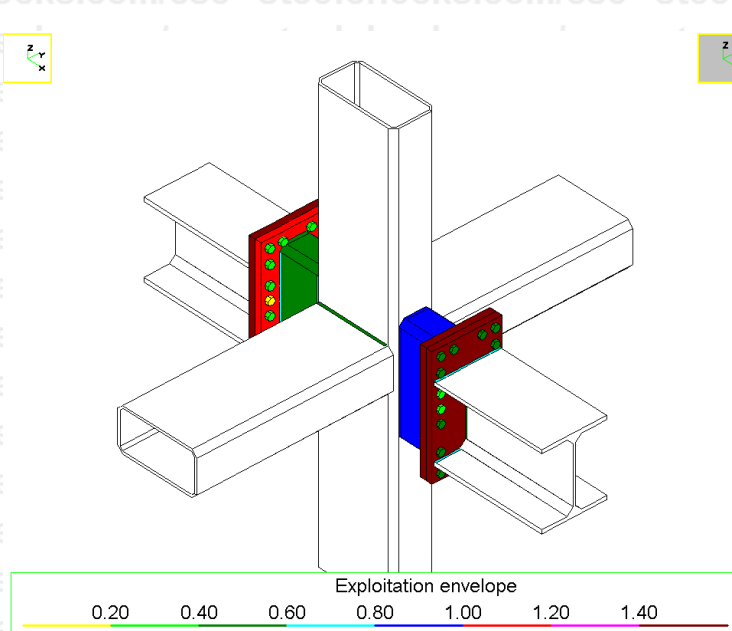

This document is related to step 4 only

# Let's consider a Renode

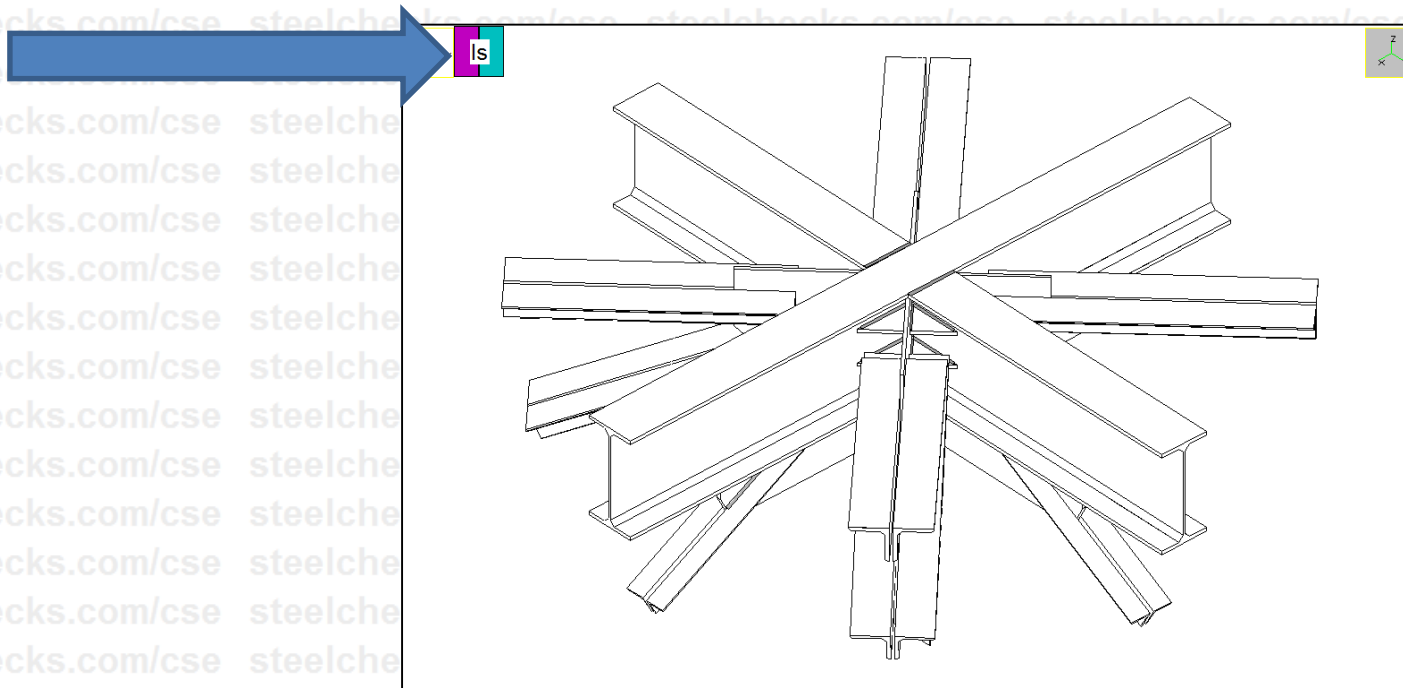

How do we move forward?

We need some “pillars” to do that.  
 I don't like “adhoc-eries”, as De Finetti did call them.  
 We don't want to be fooled by the fact that a bolt is not anymore in a “row”, or that the shape is not I or H, or rectangular or that for some reason I need unsymmetric components.  
 I think ***I don't need to know that a component is an angle to check it. I need to know its stress state.***

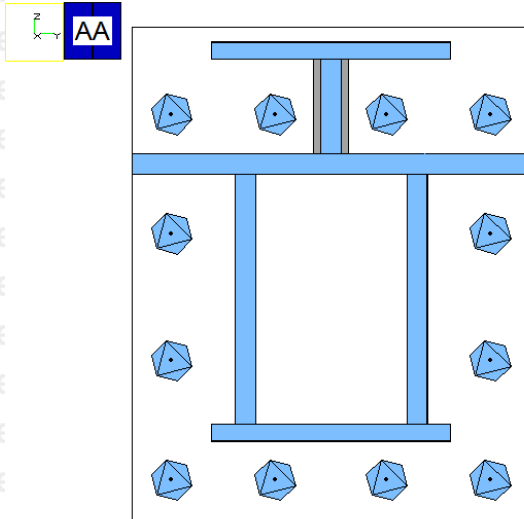
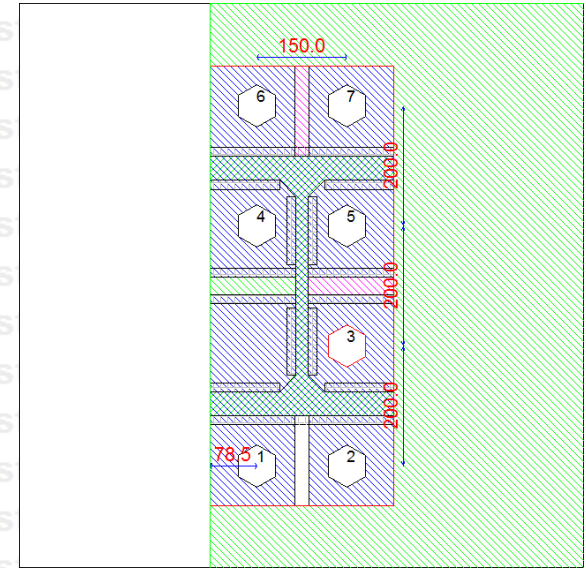

Courtesy CEN, Bochum, Germany



CSE0 - by Castalia srl - www.steelchecks.com - ver. 5.92 6/2014 - an.10/0101

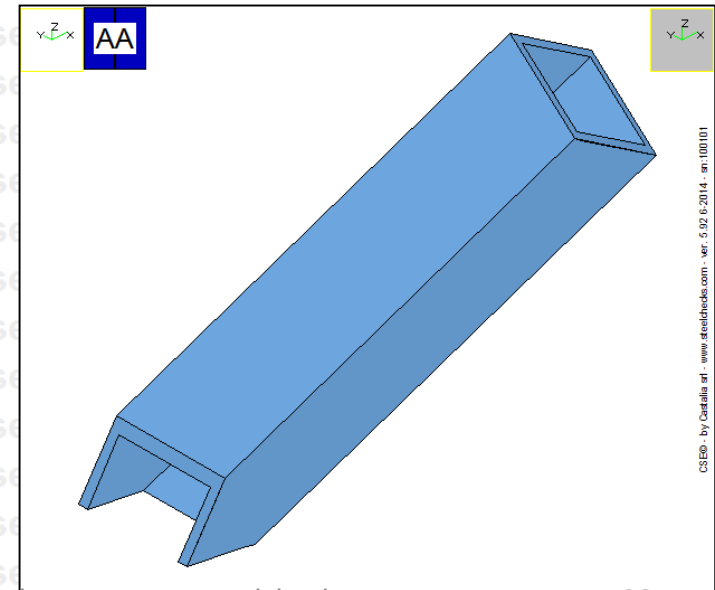

CSE0 - by Castalia srl - www.steelchecks.com - ver. 5.92 6/2014 - an.10/0101

# The PILLARS

1. The equilibrium of free body, in space, under all applied forces, must be satisfied.
2. A constraint can be replaced with the forces it exerts.
3. The action & reaction principle (Newton's) must be guaranteed at all interfaces.
4. The so called “safe theorem” of limit analysis holds true.

# The “safe” or master theorem (Lower Bound Theorem)

- “If **a** distribution of forces in the structure can be found which is in **equilibrium** with the applied loads, and if these forces everywhere within the structure are of such a magnitude that the yield stress (or yield criterion) **is nowhere exceeded**, than the applied loads are less than, or at most equal to, the loads required for collapse to occur.[...]
- For the Lower Bound to be valid a structure must be stiff enough to preclude buckling before yield occurs. In connection design, this requirement can **usually** be met by consideration of appropriate width/thickness ratios and related local buckling formulations which force the elements to yield before they buckle.”

(Thornton, 1984)

See also: Jacques Heyman, *The Stone Skeleton*, Cambridge UP→In Italy EPC 2014, translated by Paolo Rugarli (in preparation).

FEM can also automatically check for buckling and for buckling + plasticity

# Equilibrium is not enough

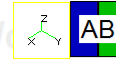

- When in by hand computation we assess that a given component is carrying some part of the internal forces, and some other not, we are deciding like God *how* the forces flow into components. We are choosing “a” balanced solution, not “**the**” balanced solution.
- If the number of unknowns is higher than the number of equations available so as to establish the forces flowing into components, I call the connection **hyperconnected**.
- If the number of unknowns is just equal, I call the connection **isoconnectd**.
- If the number of equations is higher than the number of unknowns, I call the connection **hypoconnected**.

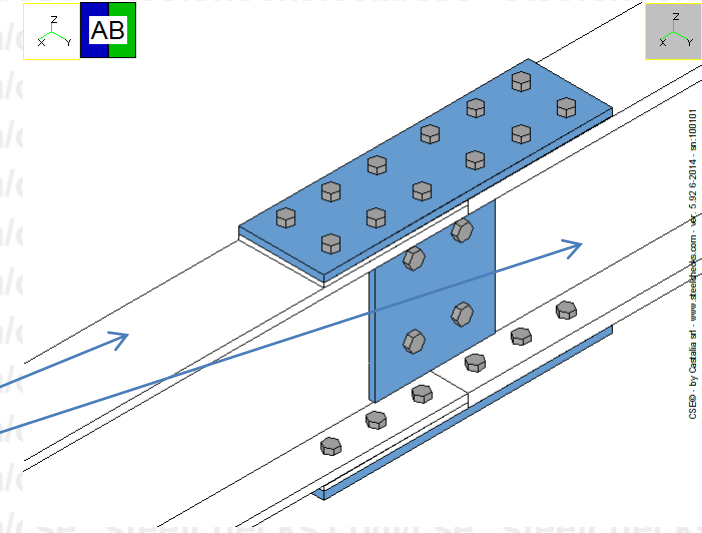

CSEB - by Castalia srl - www.castaliaweb.com - v. 5.02 (2014) - an. 000101

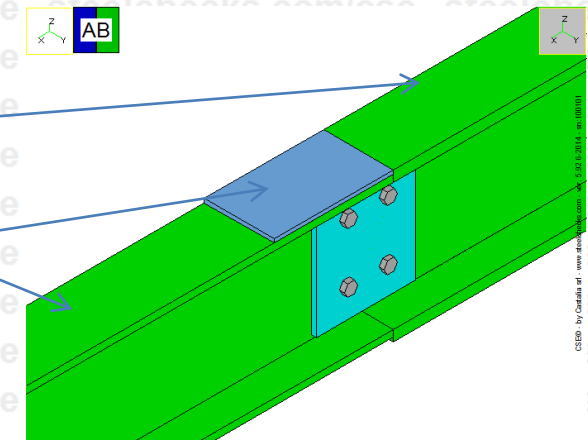

CSEB - by Castalia srl - www.castaliaweb.com - v. 5.02 (2014) - an. 000101

# Chains = Load Path

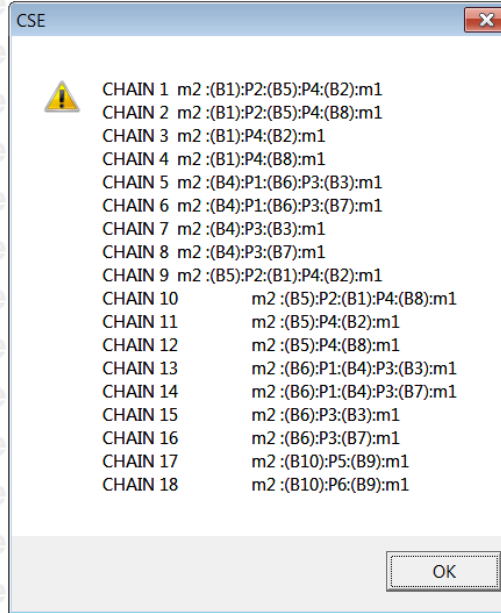
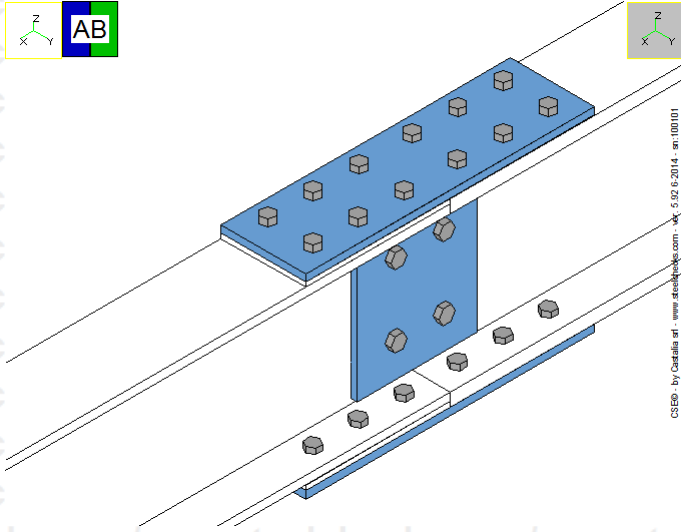
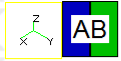

Many chains...

Hyperconnectivity

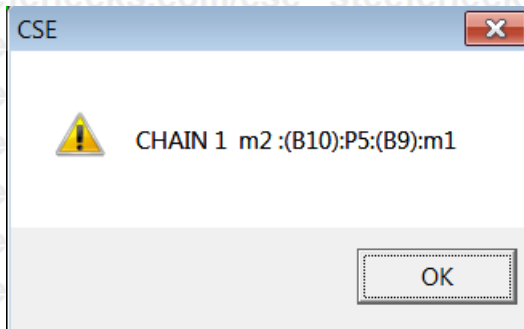
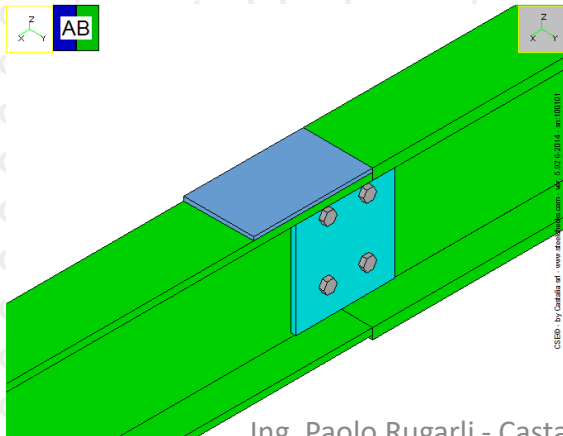
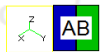

One chain,  
isoconnectivity

The selected plate is hypoconnected

slave m2 → saldatura W1 → piastra P1 → bullonatura B1 → master m1

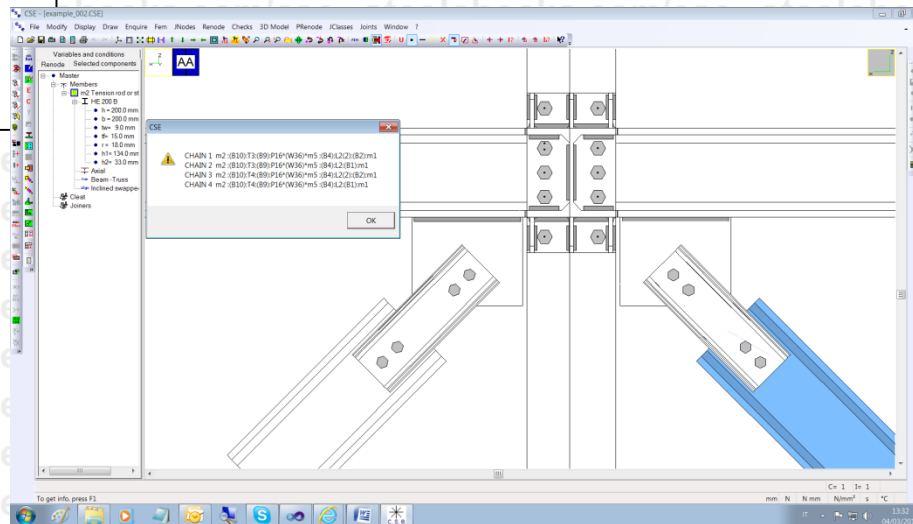
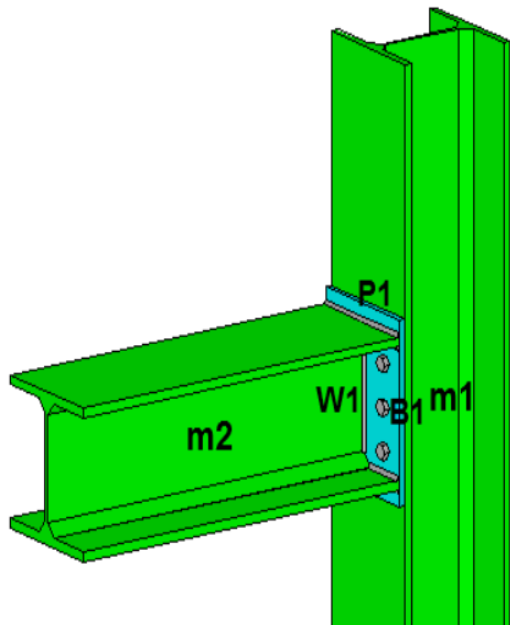

# Adhoc-eries are not general enough to establish the force flow easily

- Please explain which is which (quickly, please)
- Does *this* interfere with *that*?
- What if  $(N, V_y, V_z, M_x, M_y, M_z)_i \neq \underline{0}$ ?
- Take it easy and throw some part away... or not?

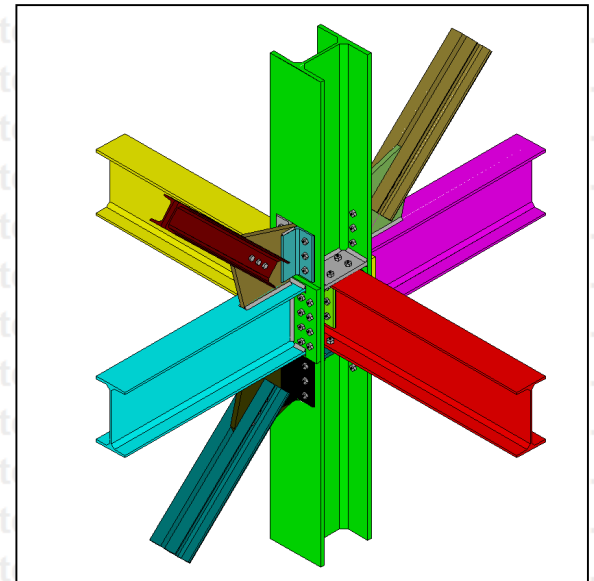

Nor they are easy to define by hand, nor once more they are easy to conceive.

Moreover, in 3D there are misalignments, or eccentricities.... (which are often **neglected**, which is for sure “**A**” way to move forward)

# So my answer is

- Prepare a suitable initial finite element model (IFEM) and get that info in such a way to automatically satisfy equilibrium.
- Then use the information to check components by applying action reaction principle.
- If some component is not checked:
  - A) Revise your check settings & methods or
  - B) Revise your design

# Which info, actually?

The forces **S** exchanged at the interfaces between different components (“joined” and “joiners”).

By definition two **components** are joined by a **joiner**. The model presently embeds: **bolt layouts** and **weld layouts** as **joiners**.

Future improvements: pure contact (no bolts&welds).

These interfaces are:

Member-**Joiner**

Through-**Joiner**

Meaningless interfaces:

**Joiner-Joiner**

**Member-Through**

**Member-Member**

**Through-Through**

My original name for “Through” was “Go between” (see Hartley and Losey’s Movie): **force messengers**

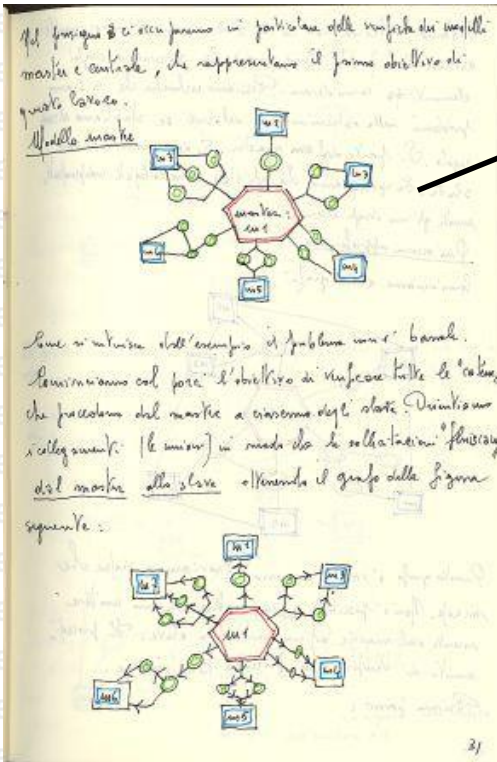

Chains

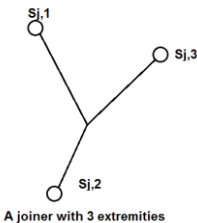

A joiner with 3 extremities

Italian friends:  
unito/unitore/membratura/tramite

Ing. Paolo Rugarli - Castalia srl - Milan - Italy  
www.castaliaweb.com -  
www.steelchecks.com



Will be managed with pure contact

# Different approaches

- 1) Hybrid fem approach
  - Single step (one IFEM, then simplified rules)
  - Multi step: (one IFEM, then simplified rules and more local SSFEM when needed, i.e. SSFEM of single components or of sets of components).
- 2) Pure fem approach (PFEM)

Both have pros & cons.

***Both have been fully automated so model creation is quite fast. The most promising today is 1), the future in the long run is 2)***

# Pure FEM

- Pros:
  - It's general
  - It's more "realistic"
  - Unifies components checks
- Cons:
  - Large models
  - If full NL, possibly high computational times (but a few load patterns can be used)
  - Unfit to check block tear and other relevant modes
  - If pushed to modelling of local gaps, contact pressure with bricks and so on, it's too precise for engineering analyses.
  - Research is still investigating about proper joiner modelling and related checks

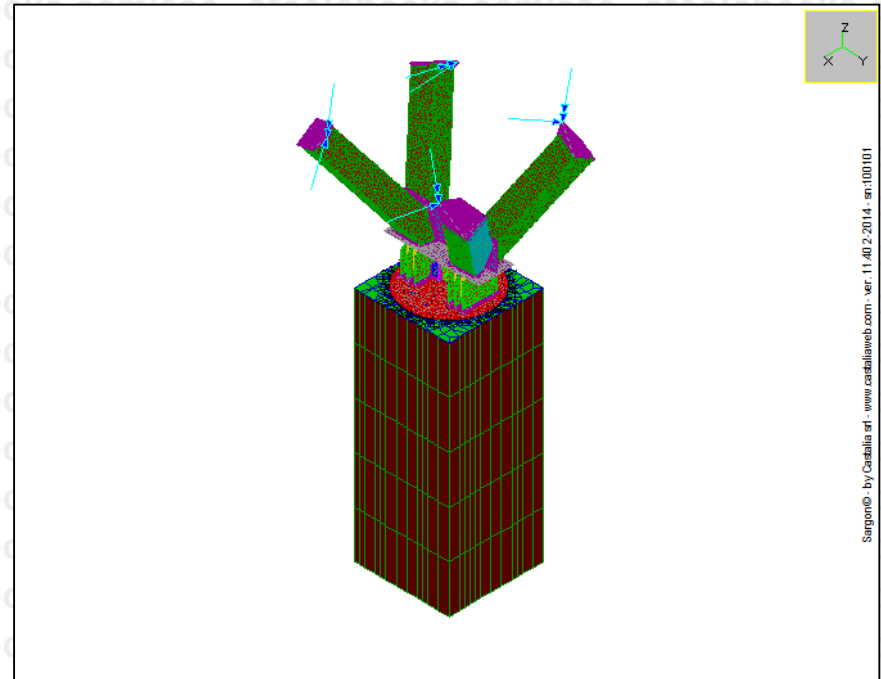

Fully automatically generated PFEM model (very fast). Contact between circular plate and r.c. column is managed via contact 2D elements → Non linear analysis needed

I do use it when needed, i.e. important connections, and/or need of in-depth analysis

# PFEM Examples

There are several possible ways to create PFEM.

Choices refer to:

- 1) Mesh size
- 2) Constraint positioning
- 3) Holes optimal modelling
- 4) Welds optimal modeling
- 5) Bolts optimal modeling
- 6) Et cetera

My research in the PFEM area is less developed than in hybrid approach. My view is that we have to find a trade off between preciseness and time.

I do use PFEM to check a subset of the failure modes, albeit in the future PFEM will be used to check all failure modes.

I do not model holes, albeit I could, as bearing pressures and block tearing is checked by other means

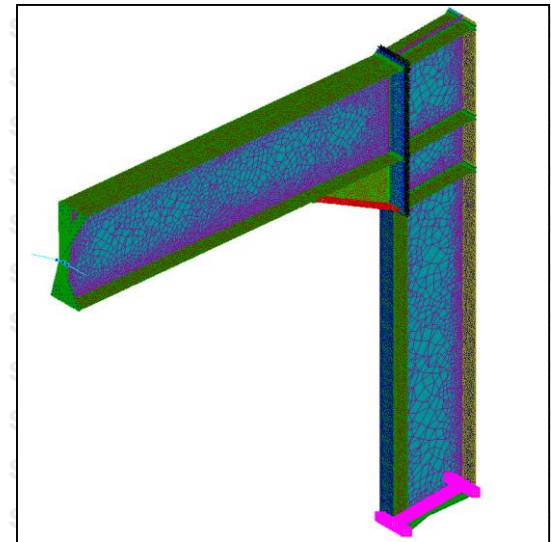
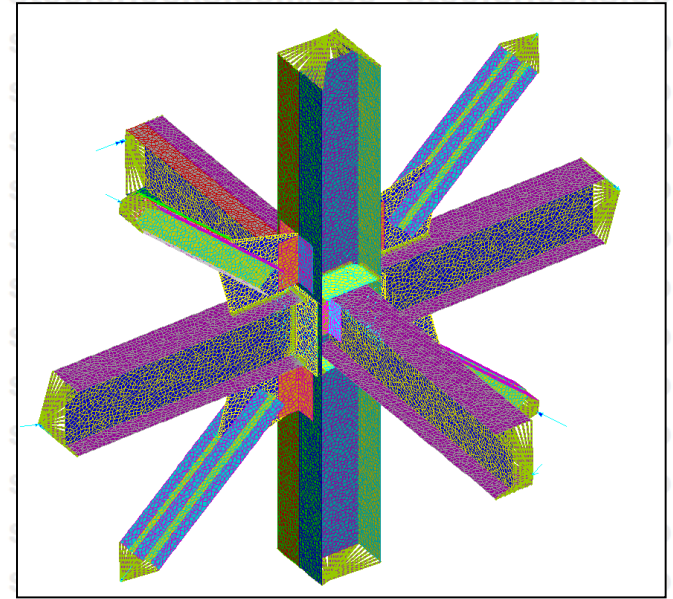

# Hybrid approach

- An initial simplified fem model (IFEM) is set up and run for all load combinations. Quite fast. Also for quite many combinations.
- The joiner forces  $S$  flowing at the interfaces, and globally balanced, are then known.
- AR principle is used to isolate each component in space under the effect of the computed global interfaces forces.
- The component is then checked against all failure modes using subforces (i.e. **elementary joiner sub-components forces computed from the joiners, interfaces global forces**).
- If needed, local fem models of components, or of subset of components are automatically created and run. The components are balanced in space, *so reactions are negligible*.

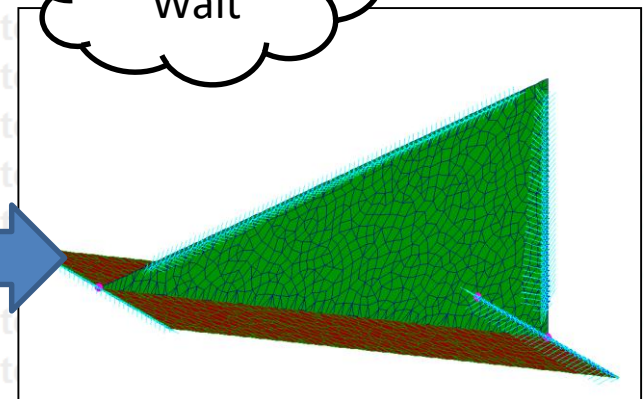
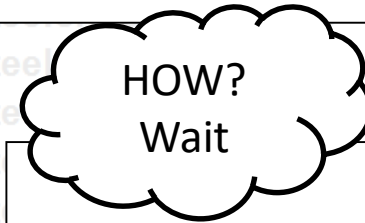
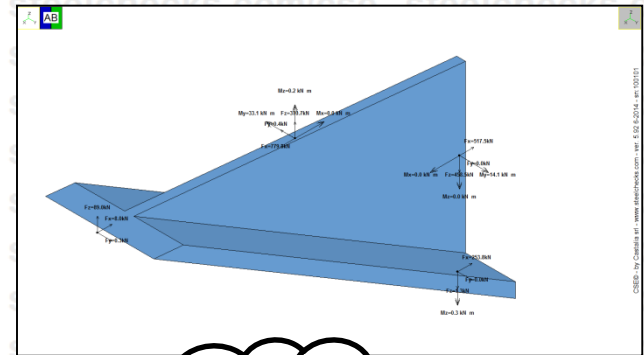

C.S.E.: Haunch under weld subforces

C.S.E.  
Forces exchanged display

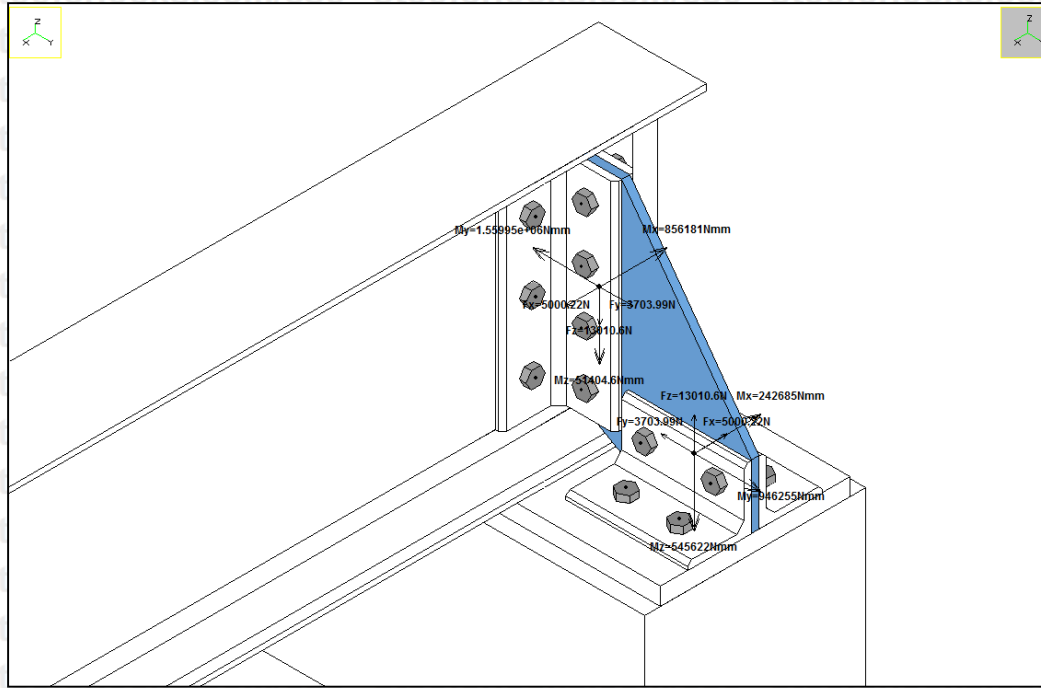

A free body in 3D space, under the effect of the (here displayed global) forces transmitted to it at the interfaces with other objects. Becomes a “loaded potato”.

A loaded potato is not an easy object to deal with:

1. Several possible failure modes.
2. Beloved beam-like checking formulae are often no longer valid or hardly applicable.
3. Geometry is an issue.
4. Bolts & welds positions are an issue
5. Loading generality is an issue
6. Local effects are an issue
7. ...and so on

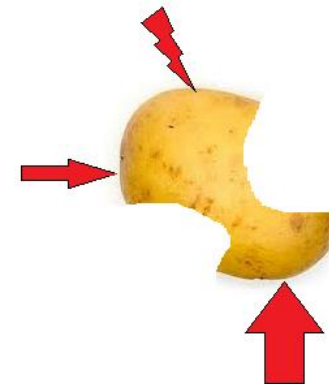
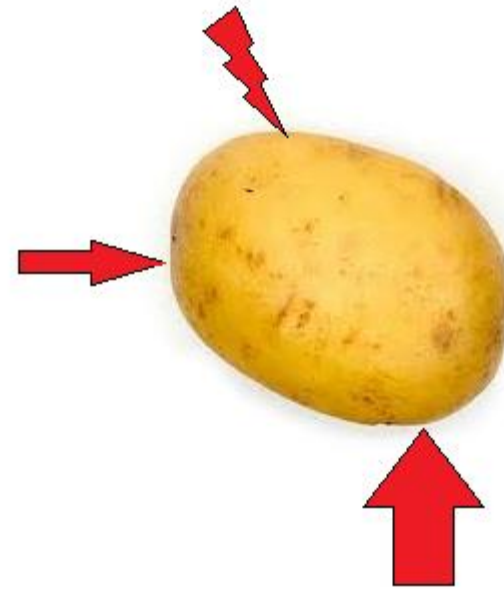

So we need general tool.

# Bolt layout definition

- A set of bolts all joining the same components.
- All the bolts do lay over a plane, **and are freely positioned over it (see aside)->**
- **They can be in rows&cols or not, every pattern allowed**
- The bolts behave in an organized manner, so that from the global forces flowing in the layout I can compute:
  - The forces flowing into each bolt shaft according to several possible laws
  - The pressure field exchanged at the bearing surface interface, depending on the bearing surface extent and on the bearing surface constitutive law (see below).
- Bolt layouts can be defined according to several choices...

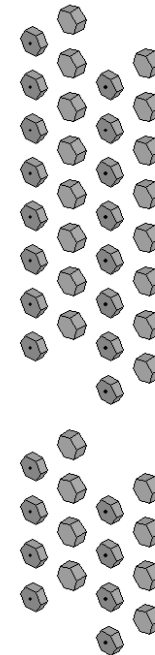
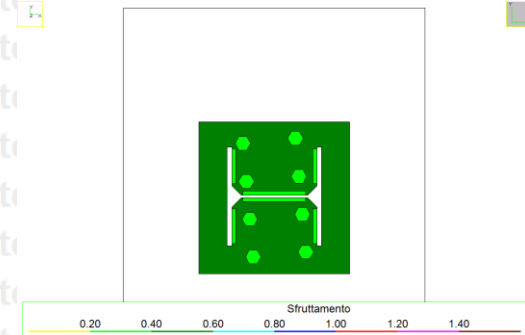

# C.S.E.: bolt layout definition dialog

**Bolt layout input**

Change...

**Arrangement**  
 Regular  Circular  
 Staggered  Free  
 Empty inside

**Regular, staggered or circular arrangement**  
 Quantity: 12 Rows, 2 Columns  
 Distances: 90 Rows, 180 Columns

**Free arrangement**  
 Add Sel/Unsel All Bolt Remove None!

**Center offset**  
 Dx: 0, Dy: 70.5, Angle: 0

**Base information**  
 70 Net length  
 30 Minimum thickness  
 1 Multiplicity

Shear only bolts  
 Compressed bolts  
 Slip resistant  
 Is an anchor  
 Use bearing surface  
 Use bolt net-area for bearing calculation  
 Add inertia of bolts in bearing calculation  
 If no bearing surface, use plastic distribution  
 Check block tear  
 Prying forces factor (>= 1): 1

Flexibility index  
Friction data...  
Anchor data...  
Bearing data...

Limit values of elementary actions  
 7931520 N N  
 6595836.6 N V  
 1609104705.25 N mm Mz  
Plastic

**Diagram:** A vertical cross-section of a bolted connection. The bolt is shown in the center, with a bearing surface indicated by a white arrow pointing to the right. Dimensions include a total width of 180.0, a distance of 60.0 from the edge to the bolt center, and a distance of 90.0 between bolt centers. The bearing surface is located 15.0 from the bottom edge.

**Face -> bearing**

ZOOM: 1: 1.0526315789  
 Font size: [ ] [ ]  
 Do not print messages  
Print... Copy Fill Hexagons  
OK Cancel Set

# How does a BL take axial force + biaxial bending?

1. By axial forces in the shaft only. No “bearing surface” (BS).



- Elastic distribution (all)
- Plastic distribution (AISC)

2. By axial forces in the shafts + contact pressures at the bearing surface.

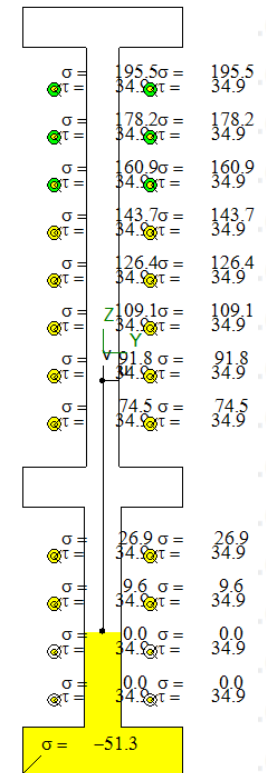
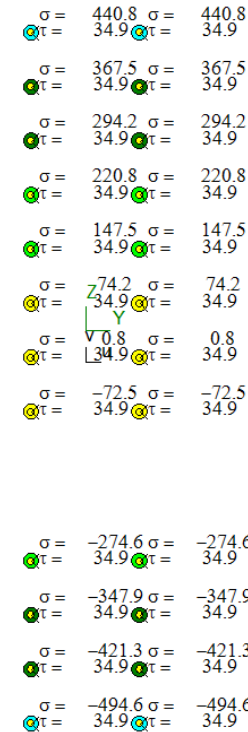



Using polygons boolean operations complex shapes can be modelled

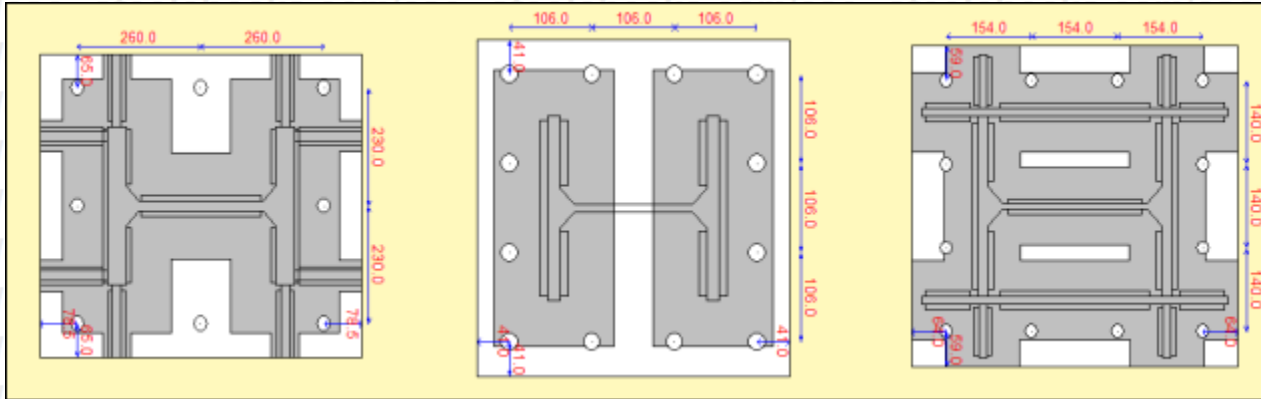

# Some more examples (BS)...

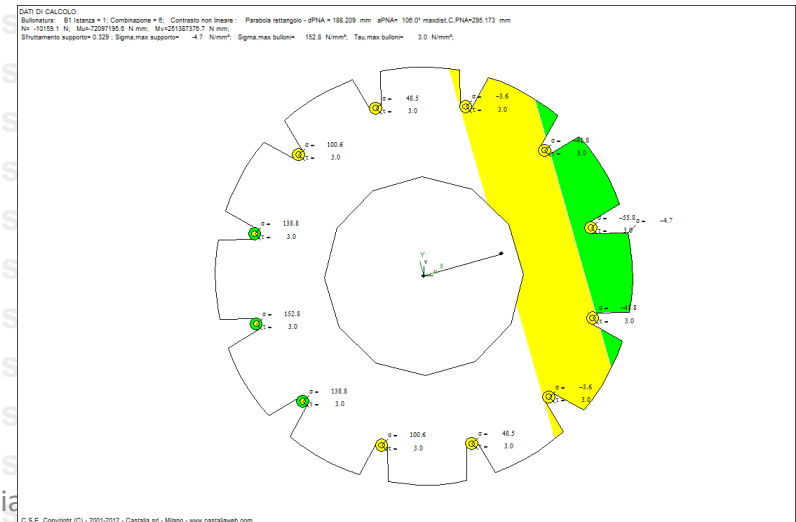
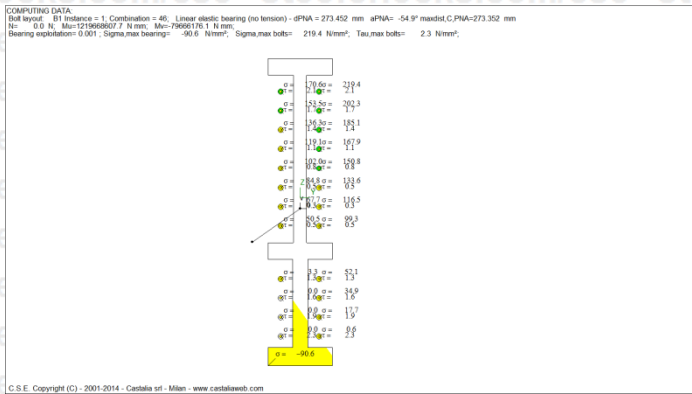
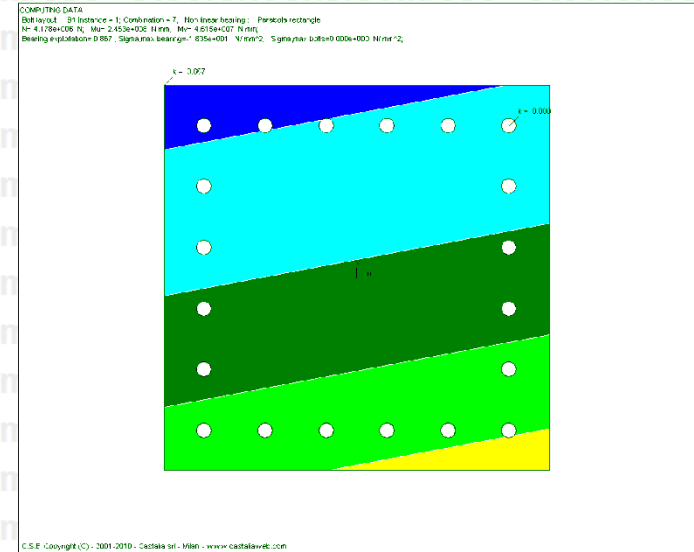
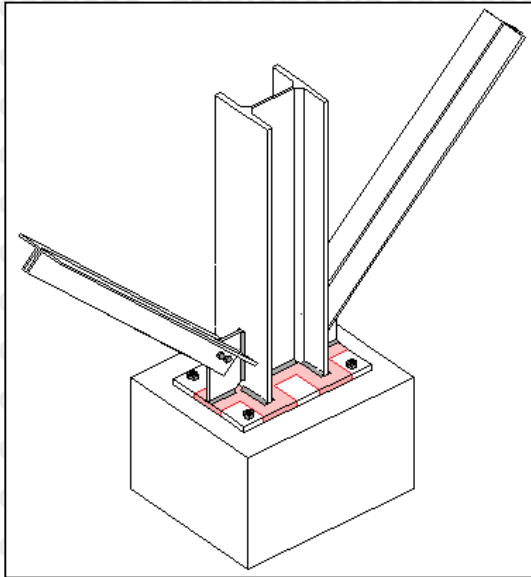

Ing. Paolo Rugarli - Castalia

- www.castaliaweb.com -

www.steelchecks.com

# Some more examples BS (2)...

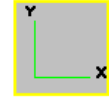
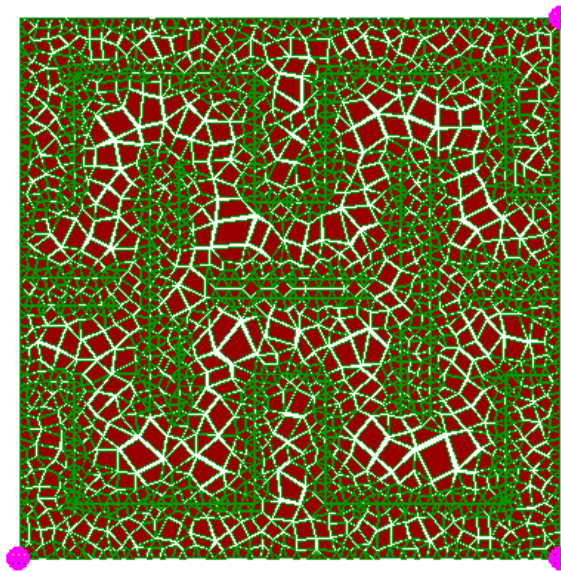
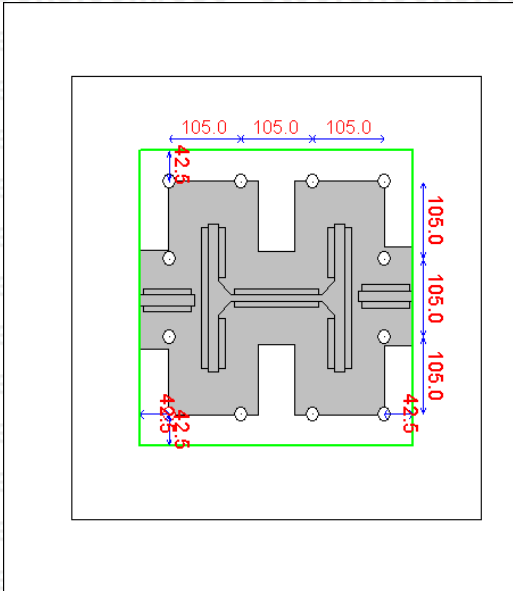

Element Research® - by Castalia srl - [www.castaliaweb.com](http://www.castaliaweb.com) - ver. 9.40 1/2010

C.S.E.: automatically prepared FEM model of a plate

The boundaries between bearing surface and not-bearing surface must be properly meshed in the SSFEM models...

# Bearing surface constitutive law definition

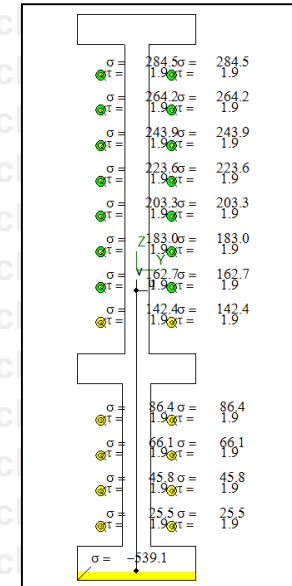
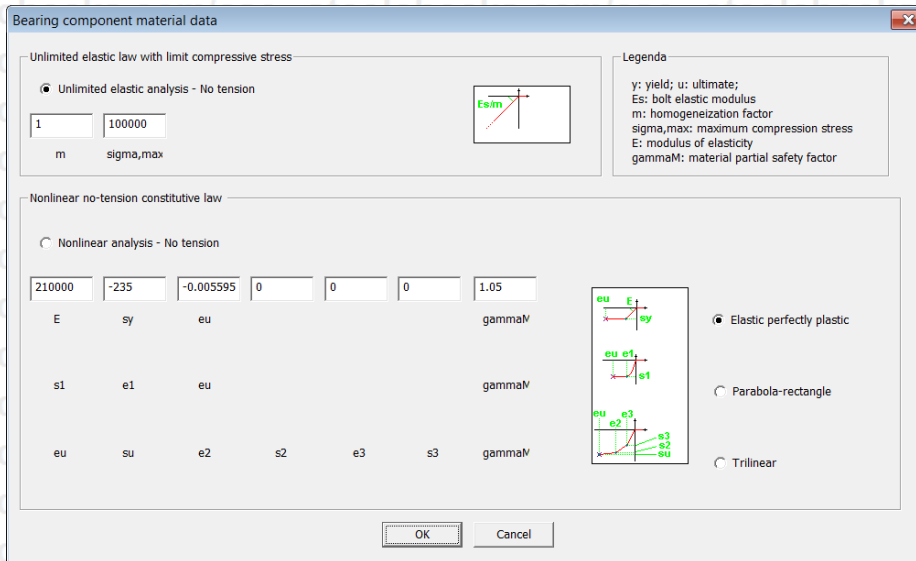

## C.S.E.: bearing surface constitutive law definition

- By selecting proper CL for the BL bearing surface, we can define the spread of the compression along the bearing surface.
- To get “true” results we would need a FEM model with contact non linearities (see below).
- We can model “edge” contact, or diffused contact.
- Pressures and forces will change accordingly.
- Local forces and pressures are computed by assuming a notional linear **strain** field.
- Bearing surface is no-tension
- A non linear analysis is performed in each load combination.
- Bearing surface intergrals are converted into boundary integrals using Green’s law.

# From BL global forces to bolt forces and pressure fields

- Shear and torque lead to shears in the shafts.
  - Linear law can be used or non linear (AISC).
  - The output are the shears in each bolt shaft (two components)
- Axial force and bending lead to axial force in the shafts and possibly bearing surface pressure fields in each combination.
- Bending moments, torque and shears may possibly lead to bending moments in the bolt shafts (optionally computed)
- These forces and pressures **may be later used to load SSFEMs**.

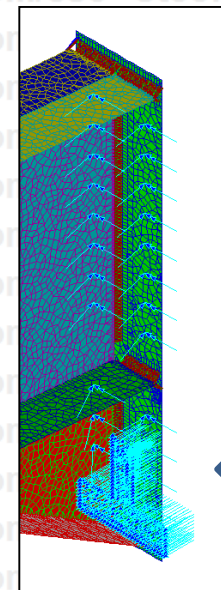
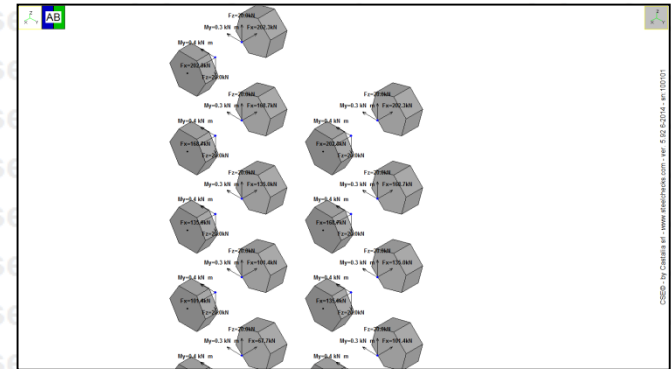

# From BL global forces to bolt forces and pressure fields

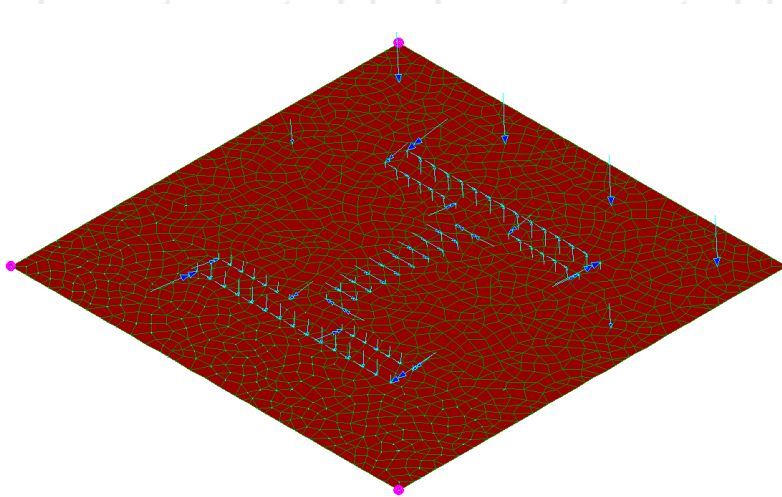

Scaled



Sargon Reader® by Castalia srl - www.castaliaweb.com - ver. 9.40.1.2010

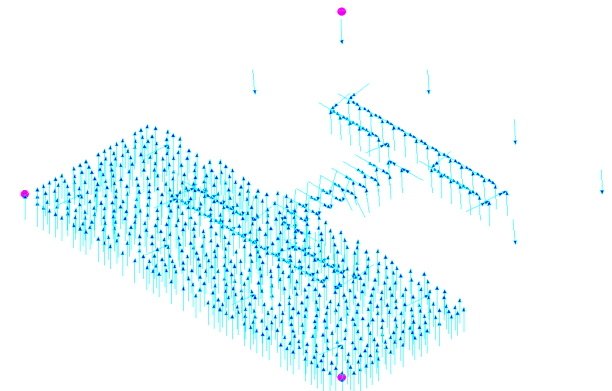

Unscaled



Sargon Reader® by Castalia srl - www.castaliaweb.com - ver. 9.40.1.2010

# Bolt Layout Checks

- Now, they are easily done according to the relevant standard (EC3, AISC, BS, IS, SNIIP, ...) by combining (N, V) effects.
- Slip resistant BL and anchors may also be computed and checked.

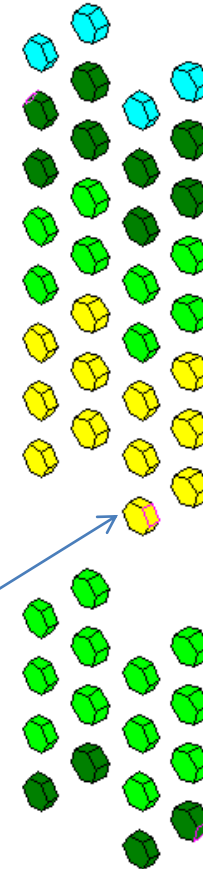

B1 - BOLT# 10 - ENV= 0.081 - CAUSE= RESISTANCE - COMBI= 3 - INSTANCE= 1

# Weld Layout Definition

- A weld layout is a set of fillet welds or of penetration welds, all welding the same (two) components.
- Fillet welds and penetration welds must currently lay over a plane.

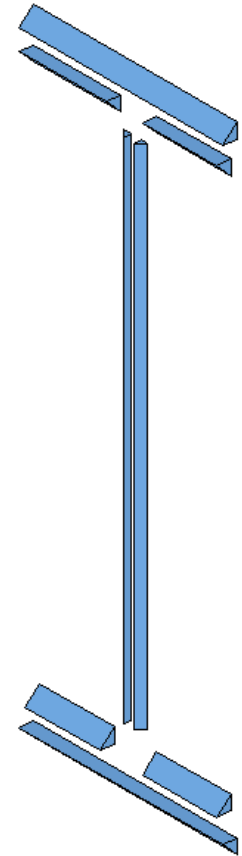

# From WL global generalized forces to single weld forces per unit length

- Commonly used rules are adopted so as to find:
  - Force per unit length in the welds (fillet WL).
  - Normal stresses  $\sigma$  and shear stresses  $\tau$  in the welds (full or partial penetration WL)

$$t_{v,i,j} = \frac{V_x}{A} - \frac{M_z}{J_p} v_{i,j}$$

$$t_{v,i,j} = \frac{V_x}{A} + \frac{M_z}{J_p} u_{i,j}$$

$$n_{p,i,j} = \frac{N}{A} + \frac{M_x}{J_x} v_{i,j} - \frac{M_y}{J_y} u_{i,j}$$

$$t_{p,av} = t_v \cos(\alpha_i - \beta) + t_s \sin(\alpha_i - \beta)$$

$$t_{p,av} = -t_v \sin(\alpha_i - \beta) + t_s \cos(\alpha_i - \beta)$$

# Weld Layout Checks

- Now they are easily done according to the relevant standard (EC3, AISC, BS, IS, SNIIP...)

W1 - ENV= 0.621 - CAUSE= RESISTANCE - COMBI= 2 - INSTANCE= 1

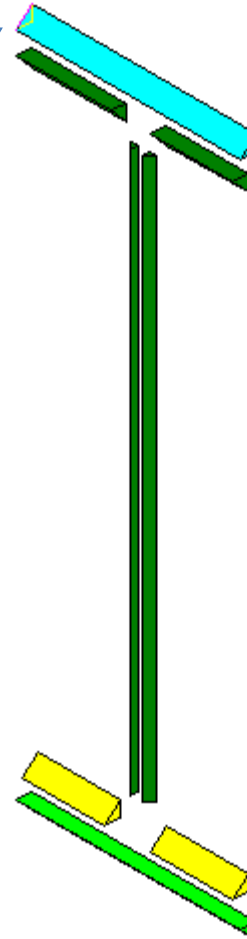

# Component failure modes

1. Bolt bearing pressure checks (easy)
2. Bolt punching shear checks (easy)
3. Pull out (easy)
4. Block tear (quite complex, see below)
5. Generic resistance checks for components (as after working processes ): very complex
6. Generic buckling checks for components as after working processes : very complex
7. Displacement control
8. Stiffness evaluation

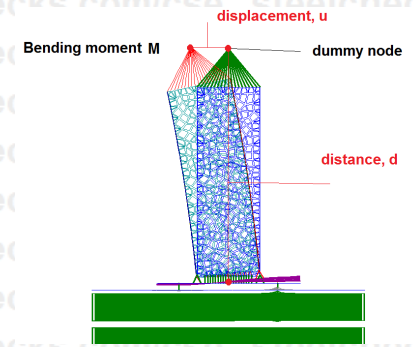
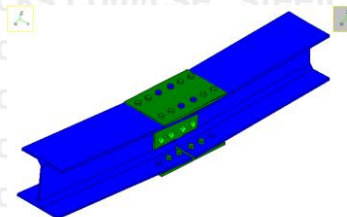
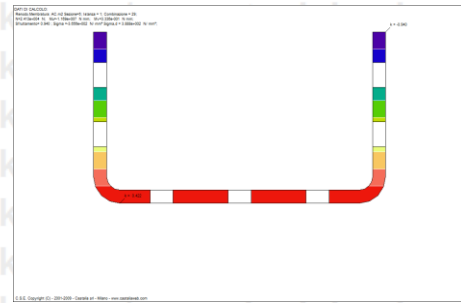
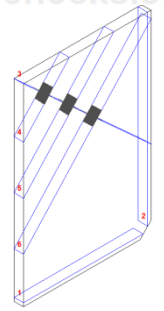
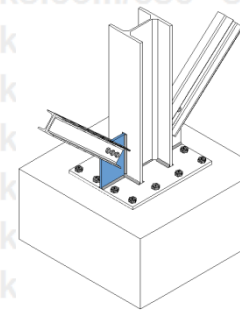
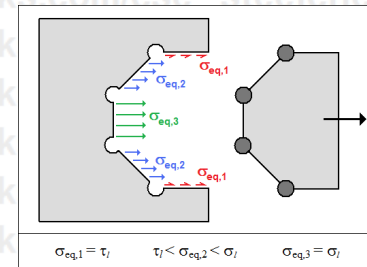
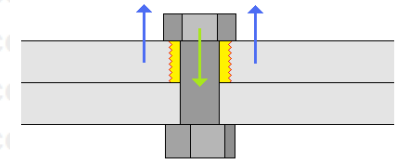
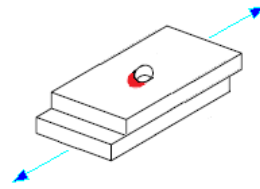

# Block tear

- Superimposing effects of shear(s) and torque leads to a complex shear distribution in the shafts.
- This stress distribution is not the one currently used in the examples available...
- Besides, in my opinion, there may be failure modes involving both shear and normal stress.

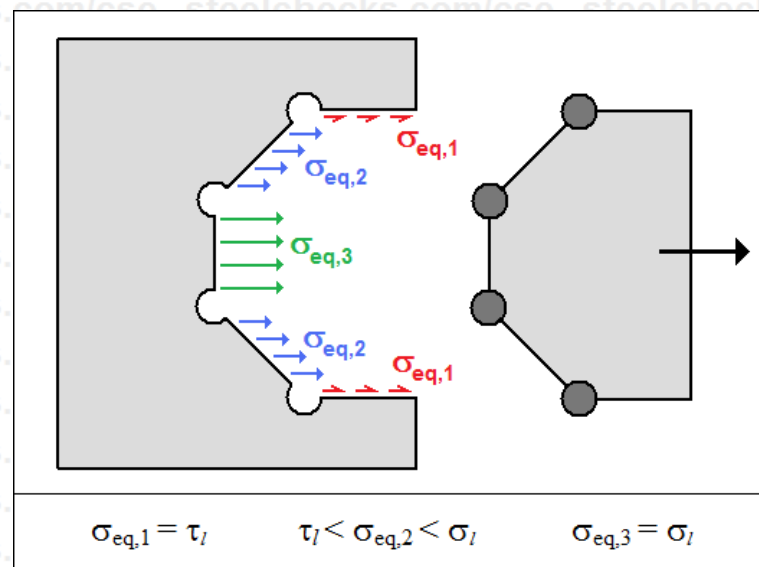
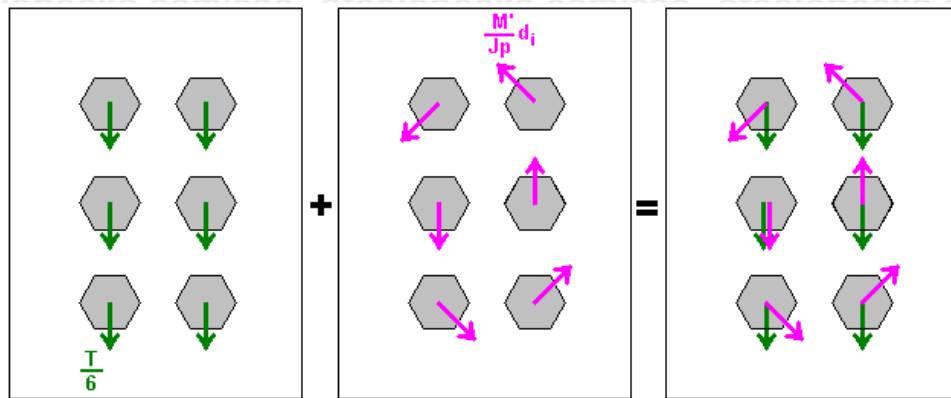

# Block tear (2)

- Depending on the subset of bolts considered R changes in module and direction.
- For each subset a high number of different possible failure paths does exist, not necessarily shear or normal
- They should all be checked and a “score” assigned to each.
- The final utilization ratio is the maximum score

$R_{subset,i} / R_{failure,subset,i,path,j}$  for all paths of all subsets.

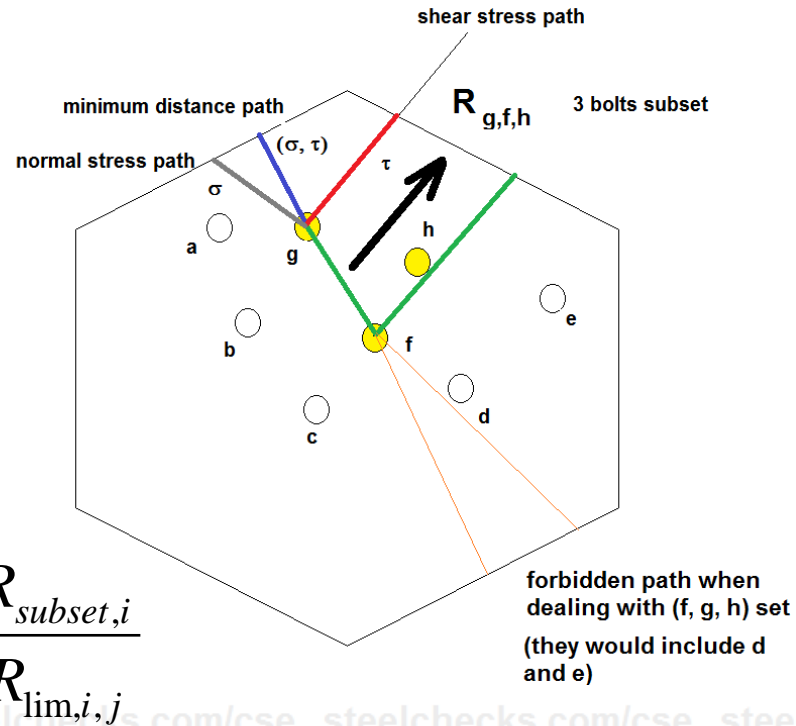
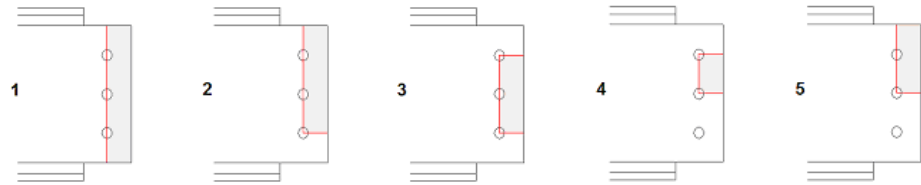

$$\frac{R_{subset,i}}{R_{lim,i,j}}$$

# Block tear (3)

- If there are 4 bolts (a,b,c,d), the subsets are:

– (a,b,c,d)

– (a,b,c)

– (b,c,d)

– (c,d,a)

– (d,a,b)

– (a,b)

– (a,c)

– (a,d)

– (b,c)

– (b,d)

The check should be done:

- For each thickness (finding a different plate shape ...)
- For each combination

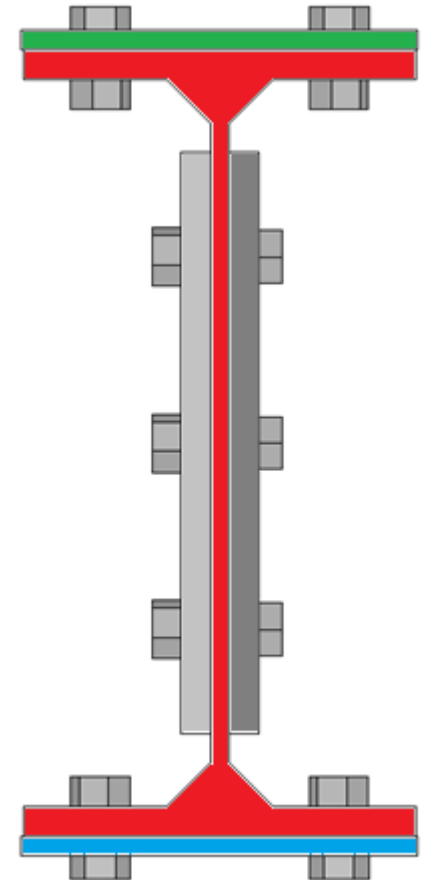

# Block tear (4)

Still unpublished results

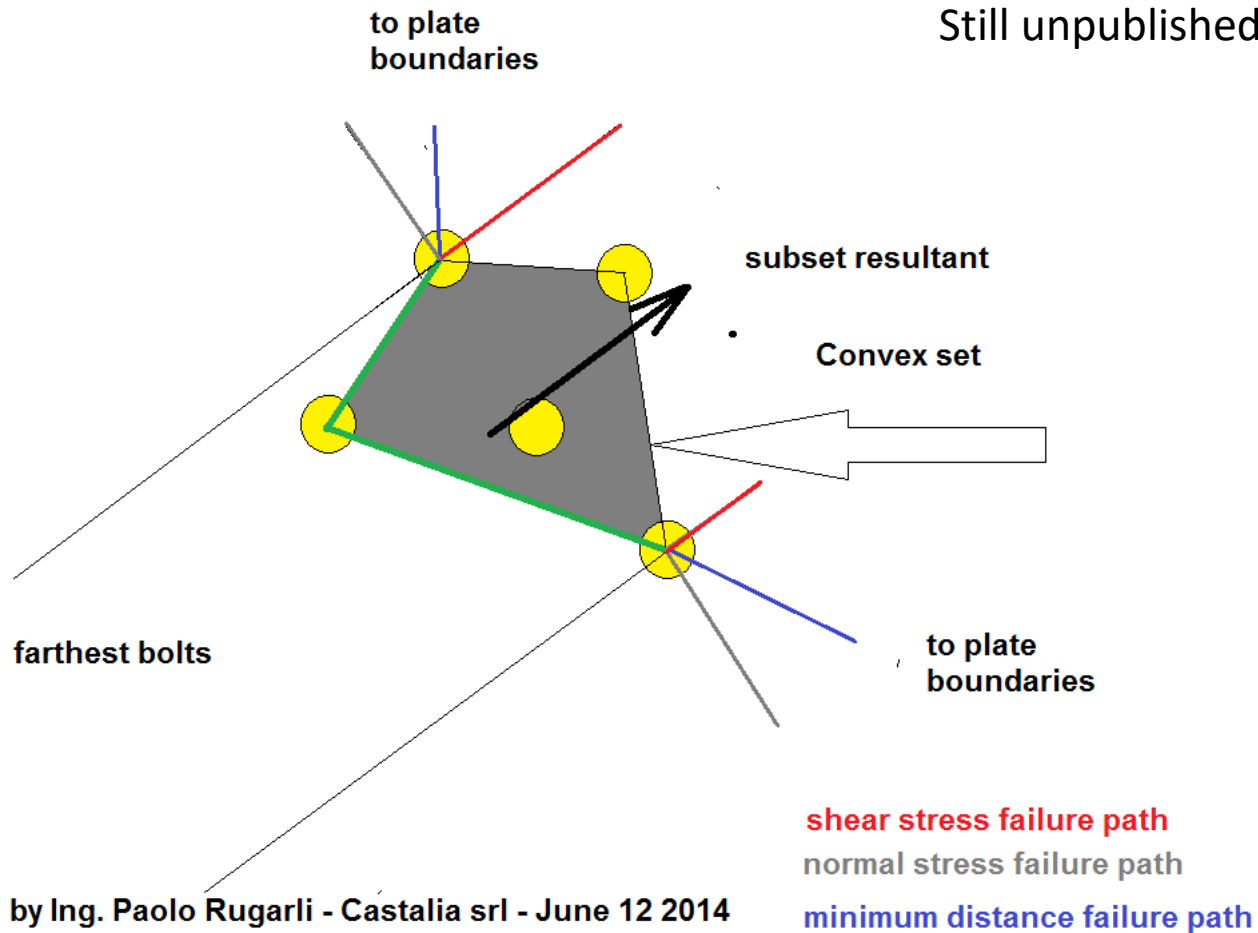

# Block tear (5)

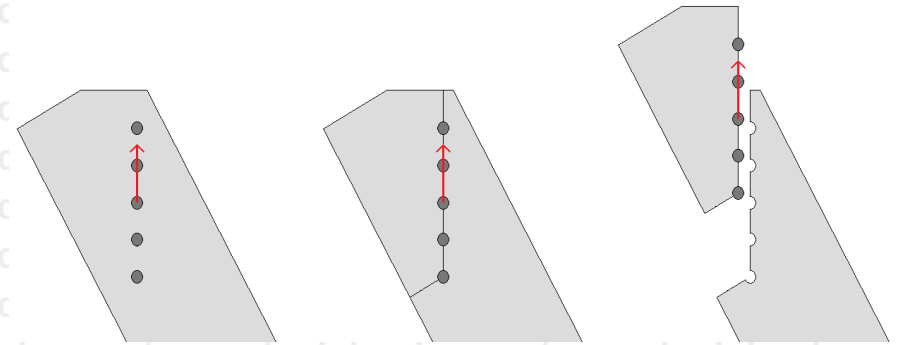
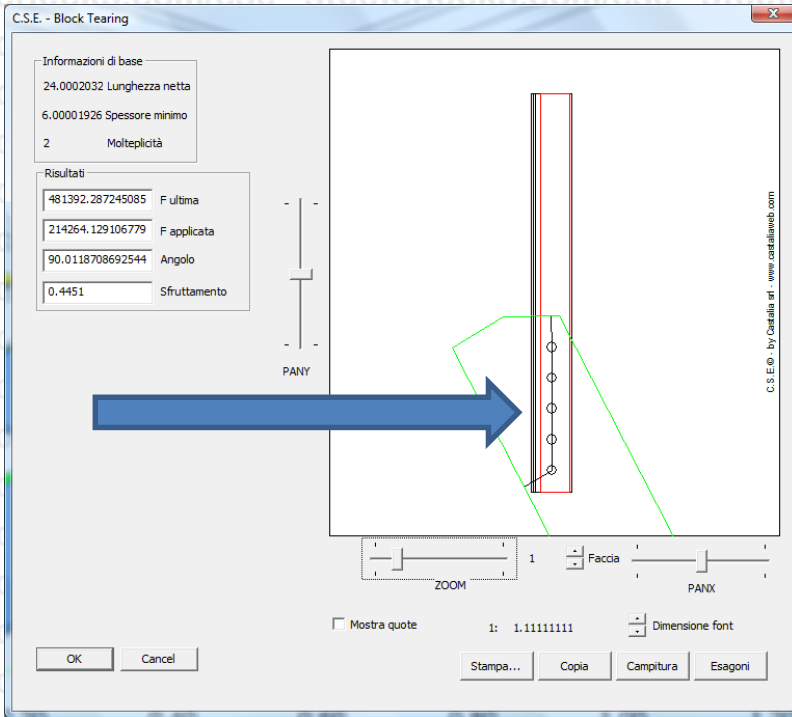

An example from a true analysis  
(courtesy Ing. Guccio Galluzzi, Florence)

# Block tear (6)

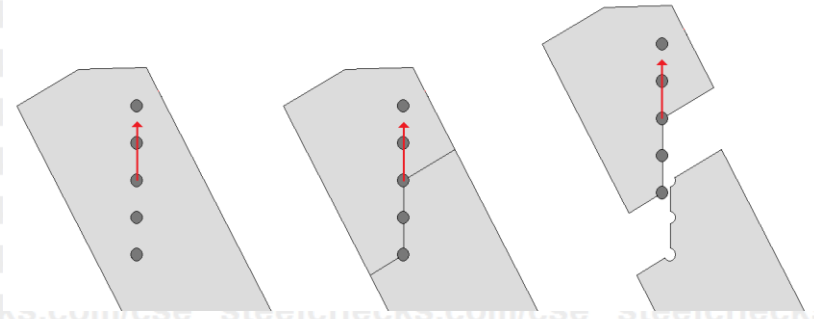
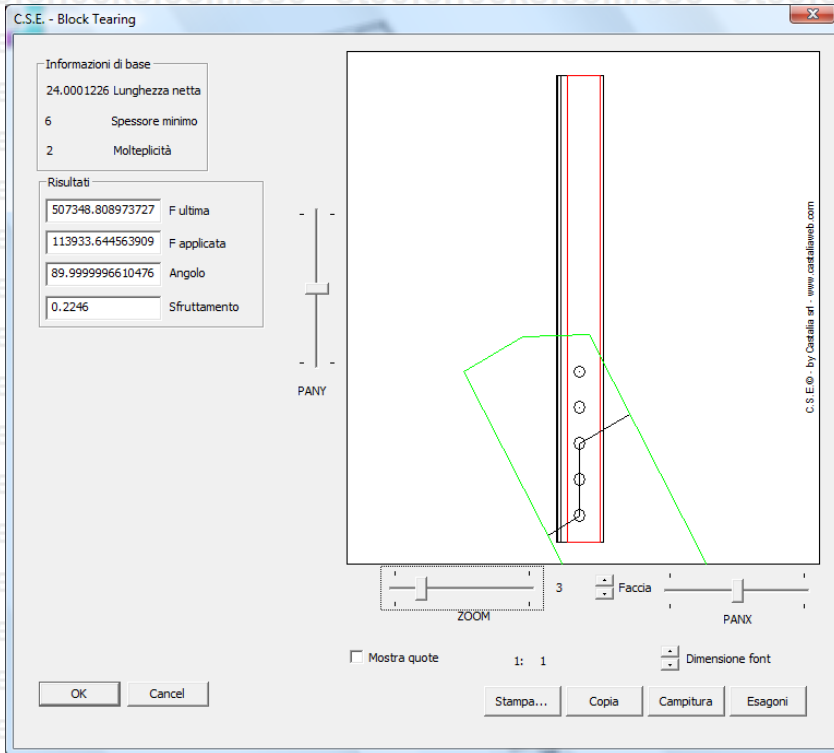

An example from a true analysis  
(courtesy Ing. Guccio Galluzzi, Florence)

# Generic Simplified Resistance Checks

- Automatic “slicing” of components. Each new net cross section is beam-like checked.
- See below “a case history”

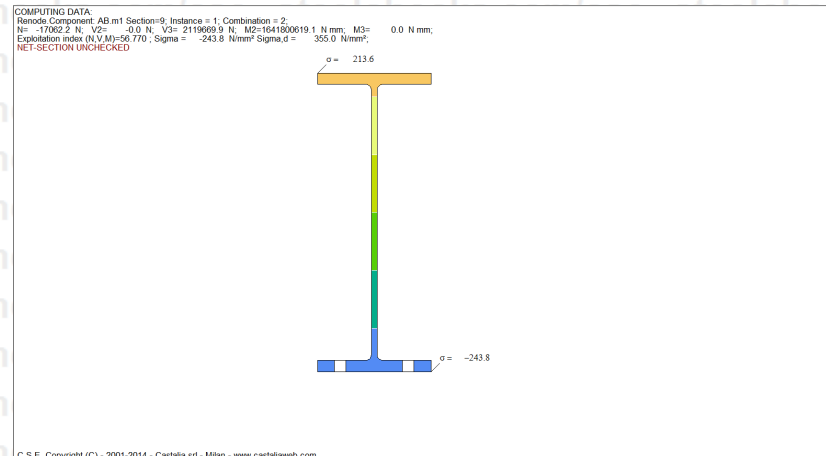
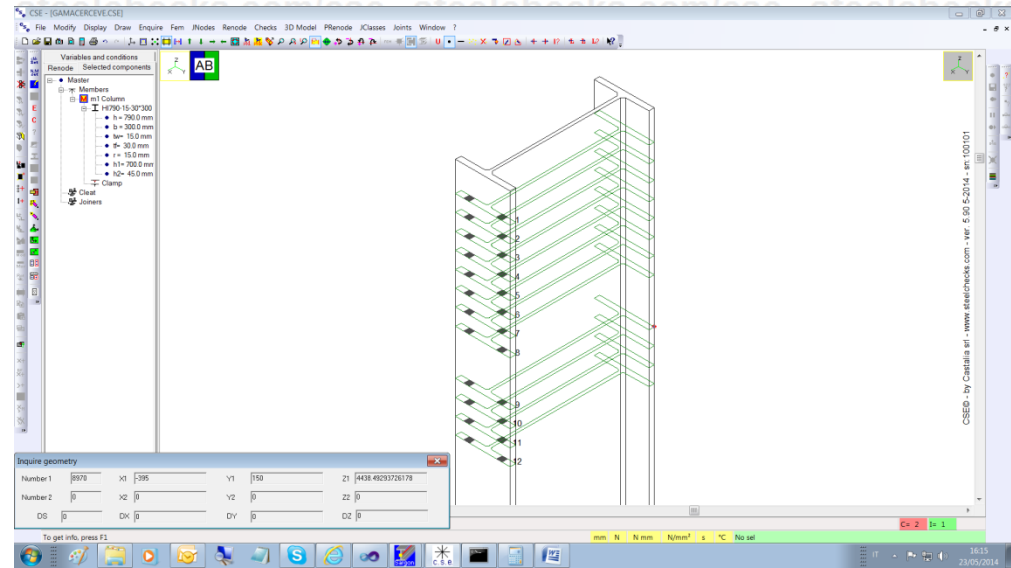

# Generic Simplified Resistance Checks (2)

- The net cross section checks
- The solid is “sliced” by parallel planes in relevant positions
- Each plane defines a “net cross section” which is found automatically.
- The effects of all the (single) forces coming from bolts, part of welds, and part of bearing surface pressures, are summed so as to get the final beam-like forces resultant.

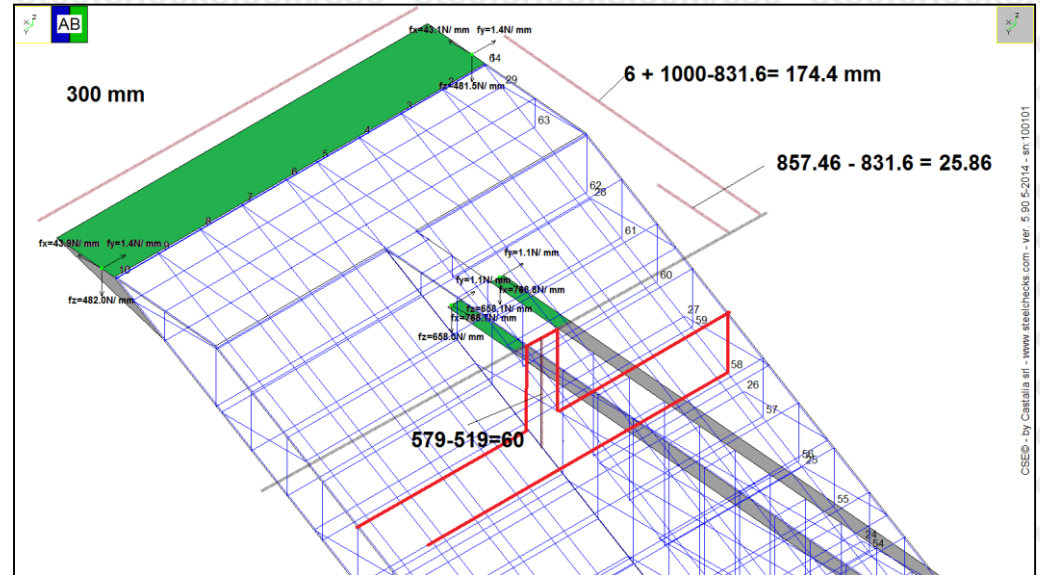

# Generic Simplified Resistance Checks (3)

- Each net cross section is then checked against beam like internal forces.
- Possible choices deal with avoiding the use of weak axis bending or torsion, but are not the default.
- If the stresses under the applied forces are lower than  $f_y$ , or if plastic check is satisfied, net-section cross check is passed. Otherwise not.

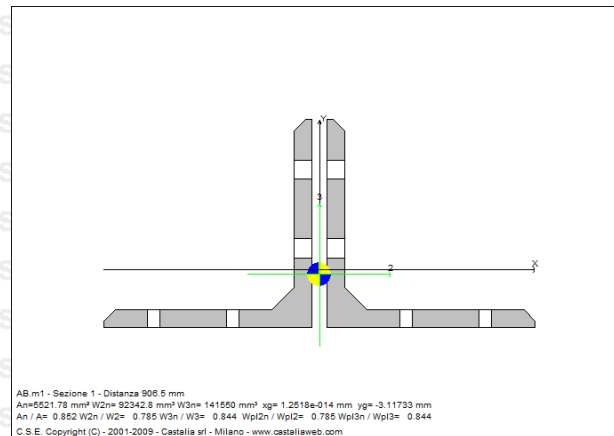
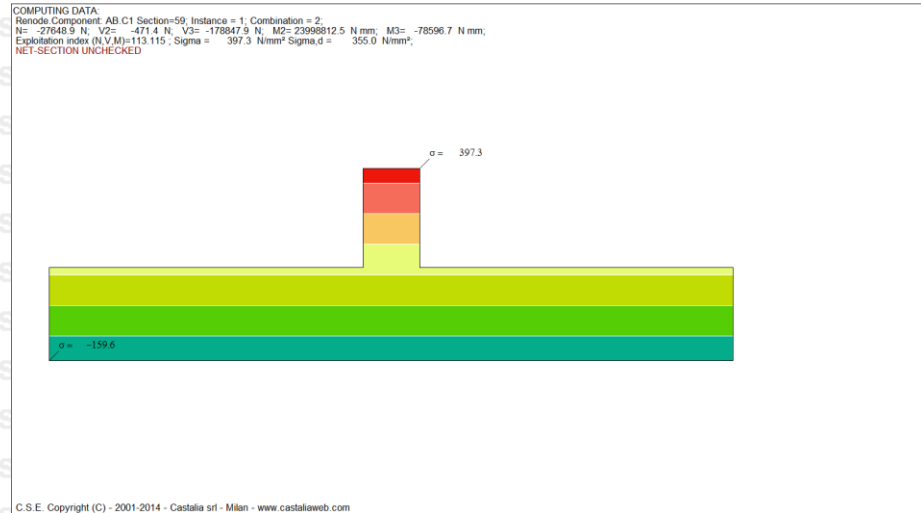

# Generic (SS)FEM Resistance Checks (1)

- A single component can be checked by means of a SSFEM. The model is created automatically and is always self-balanced, i.e. in each combination.
- The SSFEM model is a thick plate-shell (so as to get shear effects) automatically created fem model.
- The forces loading the component (here a haunch, more examples below), being self-balanced, do not require constraint reactions.
- The Von Mises stress map of the component may then be observed in each combination or as envelope of combinations.
- The engineer can then decide if the resistance checks are passed or not.
- The SSFEM may be created, ideally, also modeling holes but the choice is questionable.
- Several possible situations may arise in the single component SSFEM. →

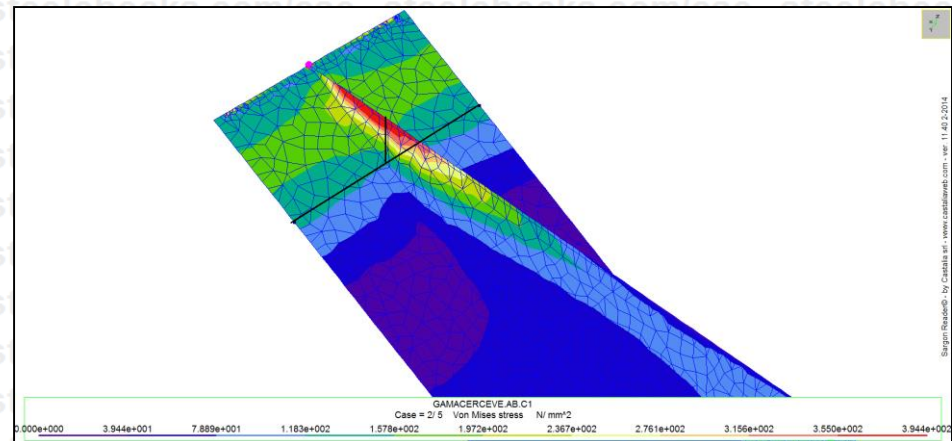
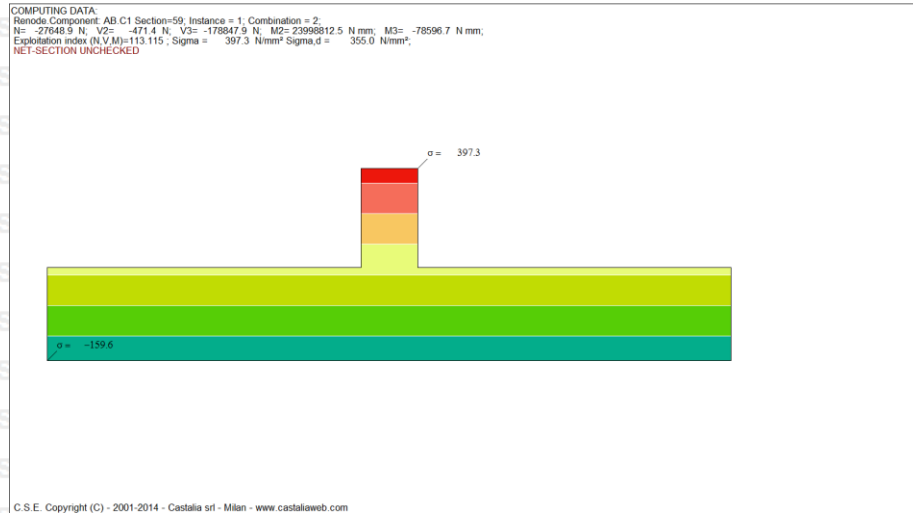

# Generic SSFEM Resistance Checks (2)

1. Everywhere in the model the Von Mises stress is lower than (factored) yield. The check is passed. **Most frequent condition!**

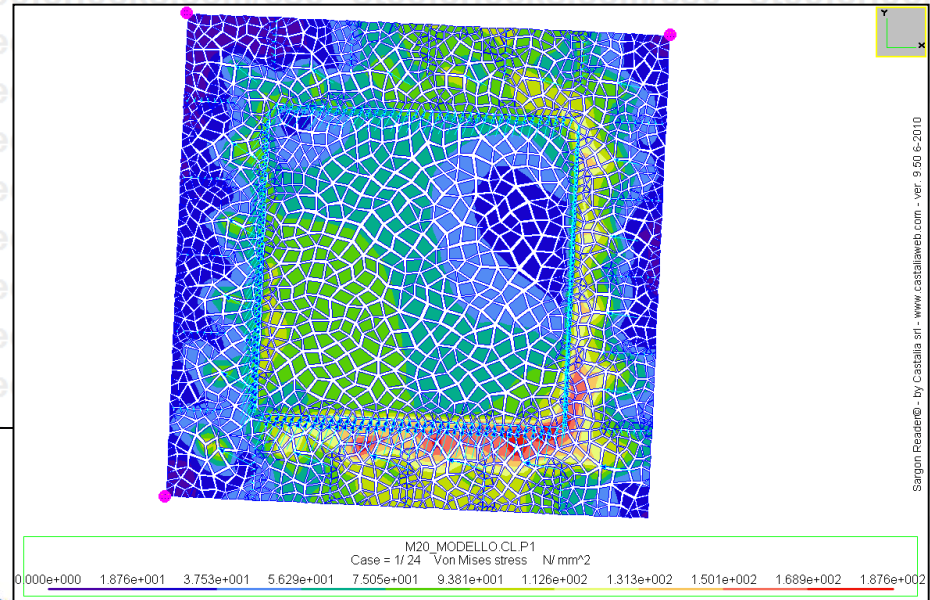
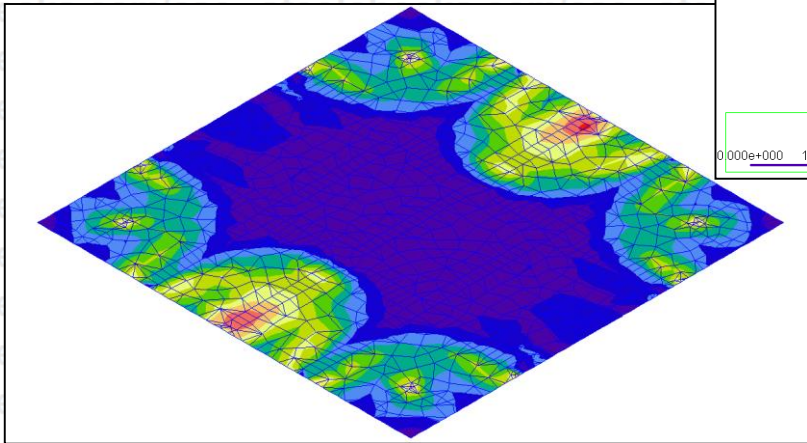

# Generic SSFEM Resistance Checks (3)

2. Some very local stress peaks are detected, possibly linked to bolt bearing pressure checks (already done) or to very limited stress concentrations. The component is checked.

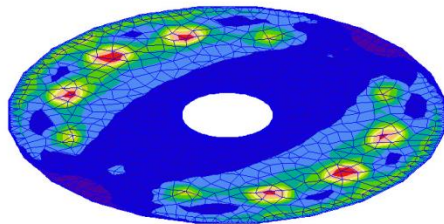
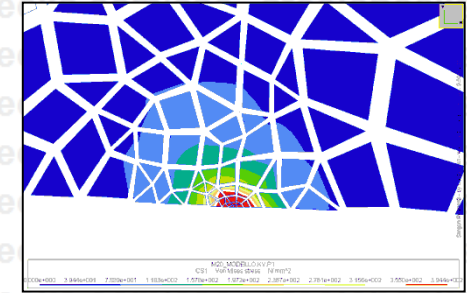
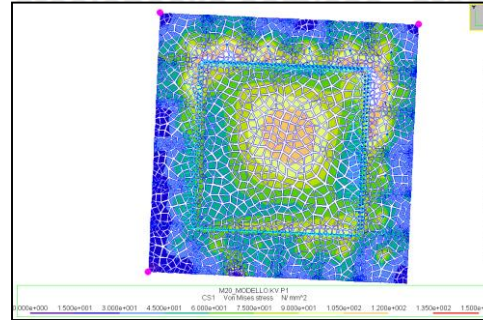

Z  
A  
Y

Surgente - by Castalia srl - www.castaliaweb.com - ver. 10.46.5-2015 - en10391

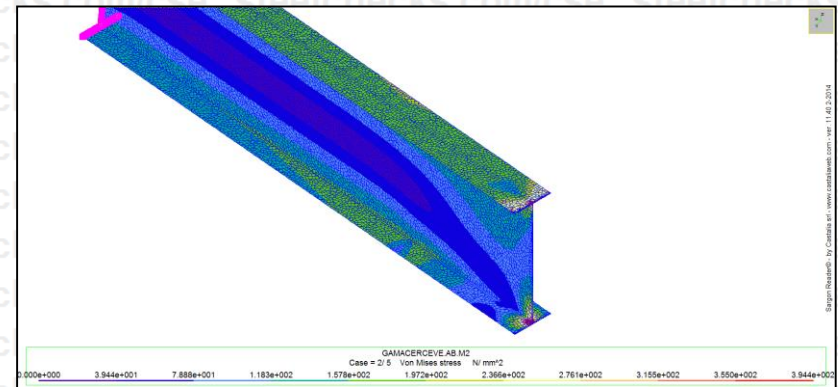

Surgente - by Castalia srl - www.castaliaweb.com - ver. 11.02.2014

# Generic SSFEM Resistance Checks (4)

3. Some relevant but not too extended part of the model has a  $VM > \text{yield}$ . The analysis must be refined in EP range, or the component must be improved.

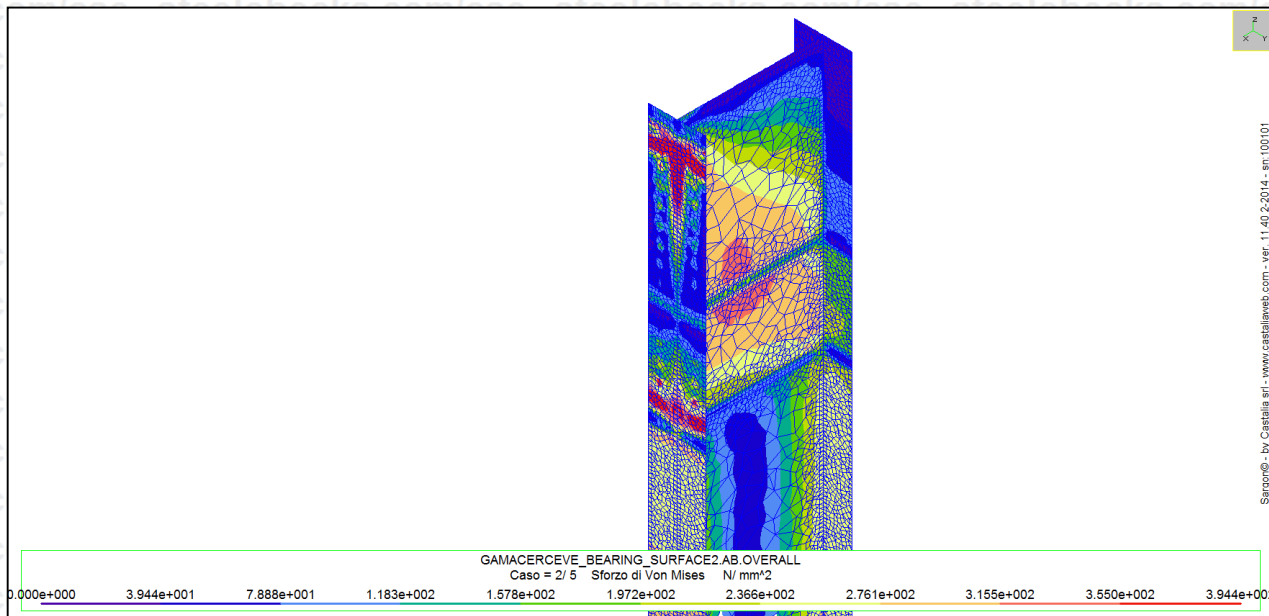

# Generic SSFEM Resistance Checks (5)

4. Relevant, very extended part of the component, are above the yield stress, probably the component is overloaded: it must be redesigned or a different load distribution must be tried.
5. The judgment cannot be nowadays automated (this is a research area). An engineer is needed.

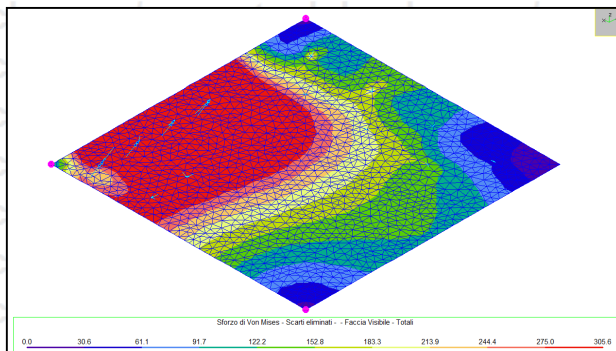
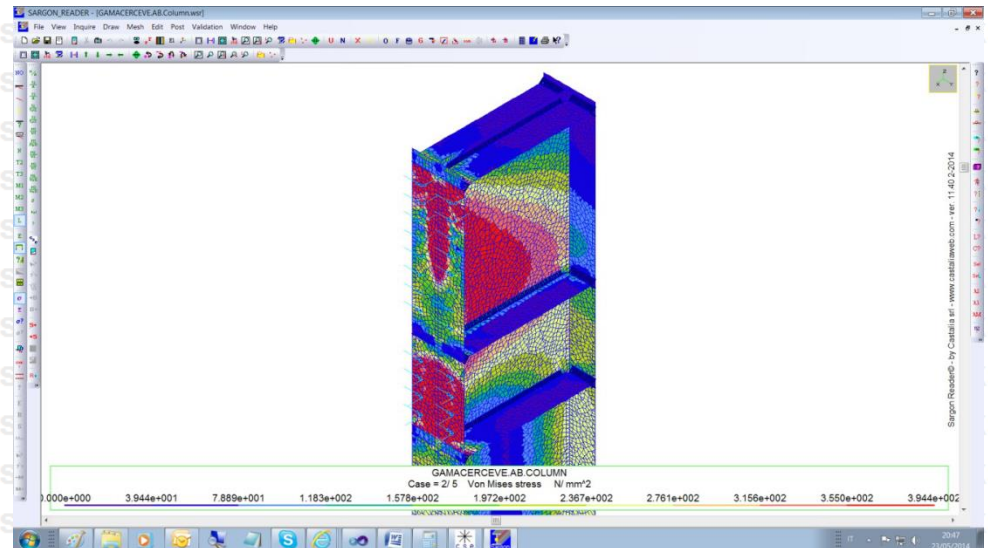

# Meaningful non linearities

- Material NL (MNL):
  - EPP (plastic flow)
  - EP (hardening)
- Geometric NL (GNL)
- Contact NL (CNL)

NLM is useless if  $VM < f_y$  or very local stress peaks

GNL is needed at engineering judgement

CNL is possibly useful for BL using bearing surface

Nonlinear Analysis settings

Load cases management (load stations)

Activate load stations (load path)

If stations are not active then restrict load cases

Convergence

Error norm

SRSS

Max abs for among components

Index

Displacement 0.001 Tolerance

Residual 0.001 Tolerance

Work 0.001 Tolerance

Divergence 50 Tolerance

Method of analysis

Full Newton-Raphson

Modified Newton-Raphson

Quasi Newton-Raphson

Number of Lobatto's integration points

10 Plates (from 3 to 12, or 20)

5 Beams (from 3 to 12, or 20)

More parameters

0.0001 Minimum modulus not-null pivots

0.005 Precision of limit multiplier

Print displacements at each iteration

Analysis strategy

Iterations

20 Maximum number of iterations per step

Step size

Pre-defined number of steps

10 Step number for each station/load case

Automatic step size control

3 Wished number of iterations

0.5 Exponent for the increment choice

0.5 Maximum increment (diambda, max)

0.01 Minimum increment (diambda, min)

Automatic decrease of step size if convergence not reached

Nonlinearity

Material

Geometric

Contact

Others

Print messages

Interpolate stresses to nodes

Arc-length

Switch to arc length if

CSP < 0.3 CSP.lim

STEP > 2 STEP.lim

Arc-length kind

Spherical

Cylindrical

Ramm

Fried

Does not stop to singular points  
CSP: current stiffness parameter

Nonlinearity

Fiber number (beam element)

250 Number per section

Return over plastic domain

1e-05 Tolerance

100 Max nb. iterations

OK Annulla Apply ?

C.S.E.: setting NL analysis

Priming: see D. Kahneman

# Some more about NL FEM (1,a): MNL

- If an EPP model is used, then if convergence is reached,  $S < S_{LIM}$ . This is the limit analysis, and covers other simplified method to assess the same.
- If an EPH model is used, convergence will always be reached, but at the cost of Von Mises Stress possibly higher than ultimate stress  $f_u$ .
- “Breaking “ of material can also be modelled by neglecting gauss points tribute to stiffness if ultimate strain has been reached.

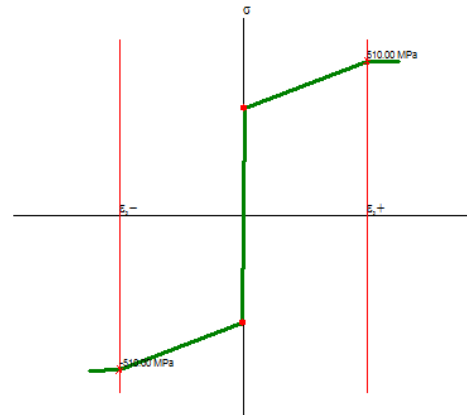
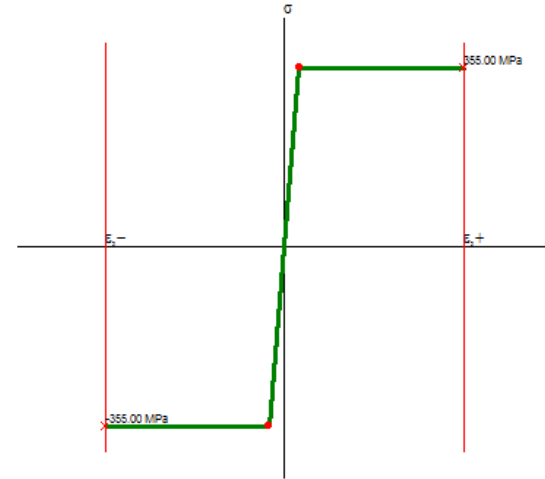

# Some more about NL FEM (1,b): MNL

- According to theory, no matter the spreading of plasticity if (at ULS) the component is capable of carrying the load we are lower than  $S_{LIM}$ .
- Increasing the plasticity areas, the convergence gets more difficult and the computational time increases.
- However, not all design must be conceived in such a way that the factored loads are at a small distance from  $S_{LIM}$ .

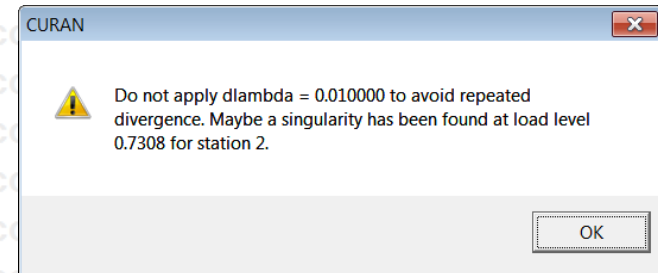
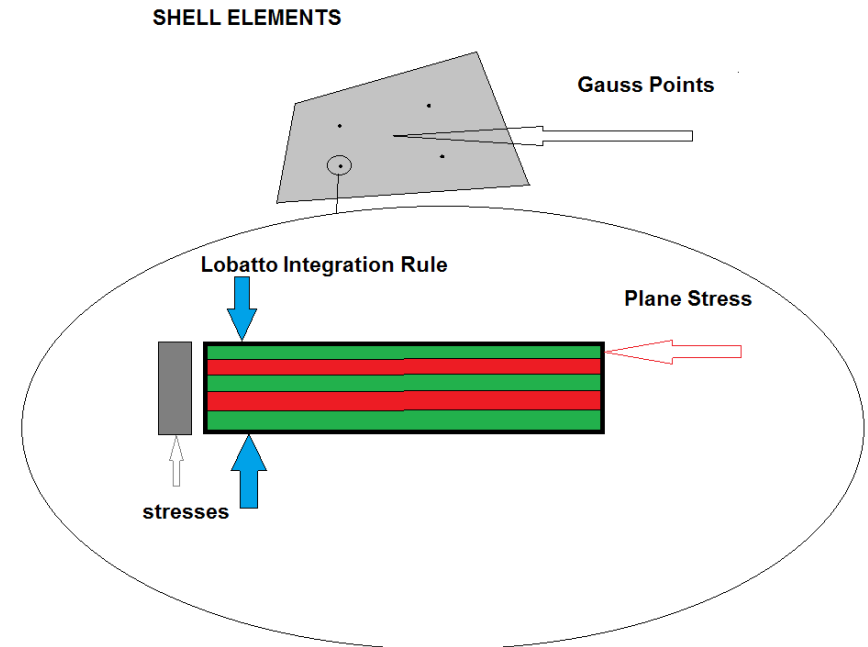

# Some more about NL FEM (2): GNL

- Geometric NL is handled by assembling  $\mathbf{K}_g$ :

$$[\mathbf{K}_{EP}(\lambda) + \mathbf{K}_g(\lambda)]\Delta\mathbf{u} = \Delta\mathbf{p}$$

- By running GNL analysis one can assess if there are possible buckling phenomena coherently with the applied fem modelling.
- Especially useful for “nonstandard” geometries, which are almost all....
- The analysis may NOT converge. If it converges we are below the limit.

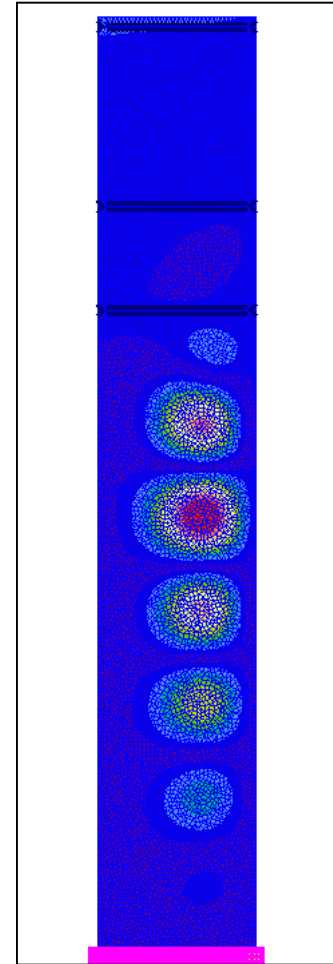

# Some more about NL FEM (3): CNL

- Ideally CNL should always be used.
- It leads to an increase in bolt axial force.
- The pattern is never easy. All the models are “wrong” including those of the standards.
- Target elements & contact elements

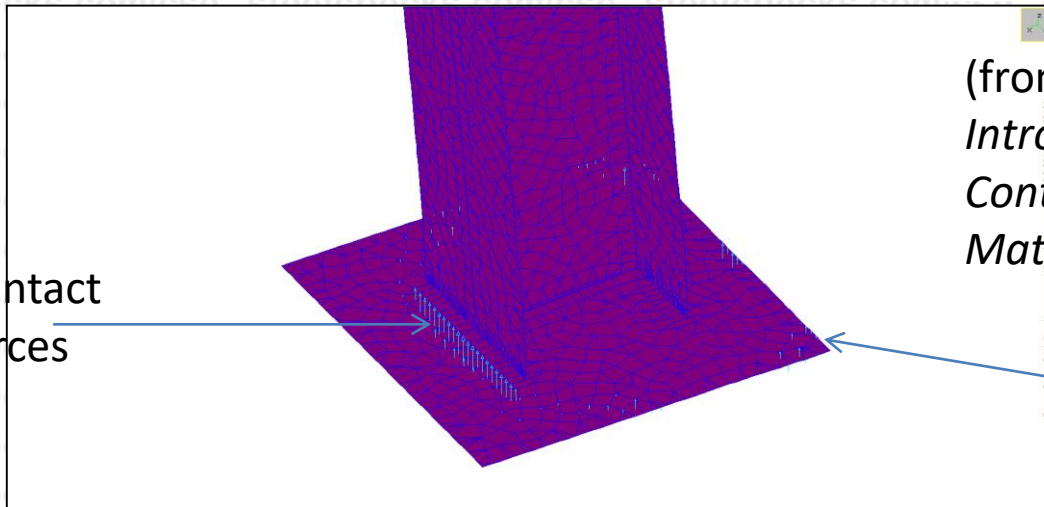
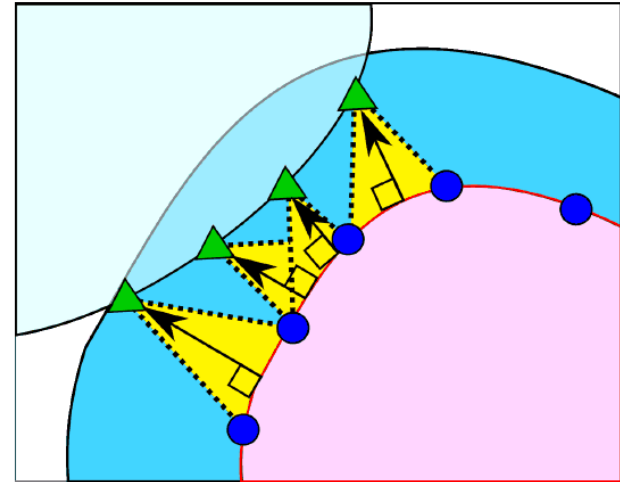

(from V. A. Yastrebov,  
*Introduction to Computational  
Contact Mechanics, Centre des  
Materiaux, MINES, Paris Tech*)

# Some more about NL FEM (3): CNL

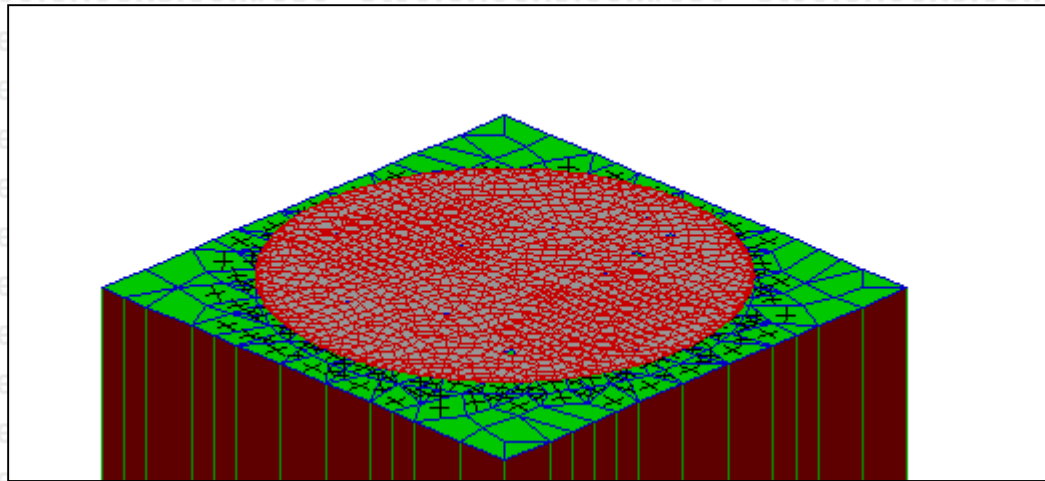

The two surfaces can be differently meshed. Signed “cross” elements are the automatically-detected possibly target elements.

# Available simplified formulation for PF

Prying forces factor setting

Data

24	d	60	a
26	dh	70	b
320	p	234.99952	Fy

alpha is a function of t

t is a function of alpha

28.922487	t
0.256	alpha

0 no prying      Alpha      1 max prying

Results

0.8513261223	T,max / B
1.1746379838	K,prying

Update!

$$K_{prying} = 1 + \frac{\delta \alpha}{(1 + \delta \alpha)} \frac{b'}{a'}$$

$$\delta = 1 - \frac{d_k}{P}$$

$$a' = a + 0.5d$$

$$b' = b - 0.5d$$

$\alpha = 0$  no prying forces

$\alpha = 1$  max prying forces

B = max N, bolt

W. Thornton - 1985 - AISC

Initially t is set as the minimum thickness of connected objects

If the existing thickness is used, a given value of alpha is determined, and so a value for K,prying

If a desired value of alpha is set, then the required thickness will be read accordingly

T,max / B < 1 means a part of B is required to resist prying force Q

A stiffened plate may be modelled with a high thickness value

OK      Cancel

C.S.E.: setting of prying forces factor

This model is applicable only to a very limited subset of situations

Ing. Paolo Rugarli - Castalia srl - Milan - Italy

- www.castaliaweb.com -

www.steelchecks.com

# An example of CNL

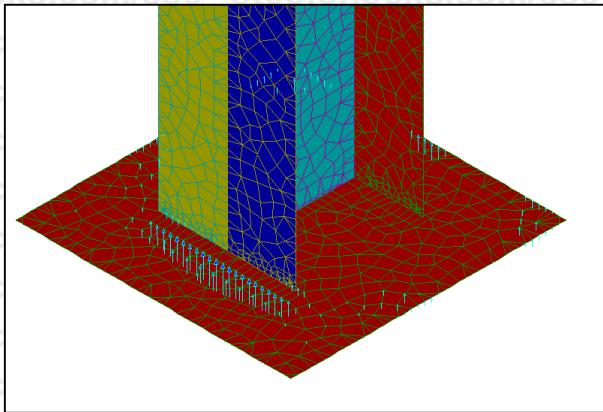
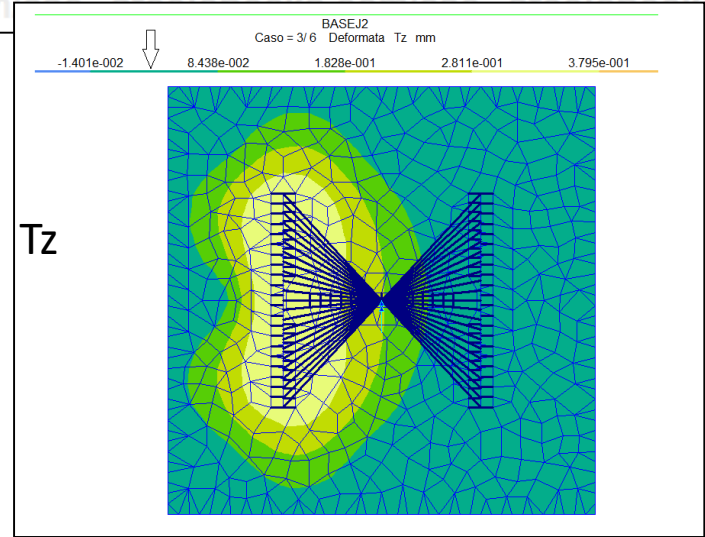
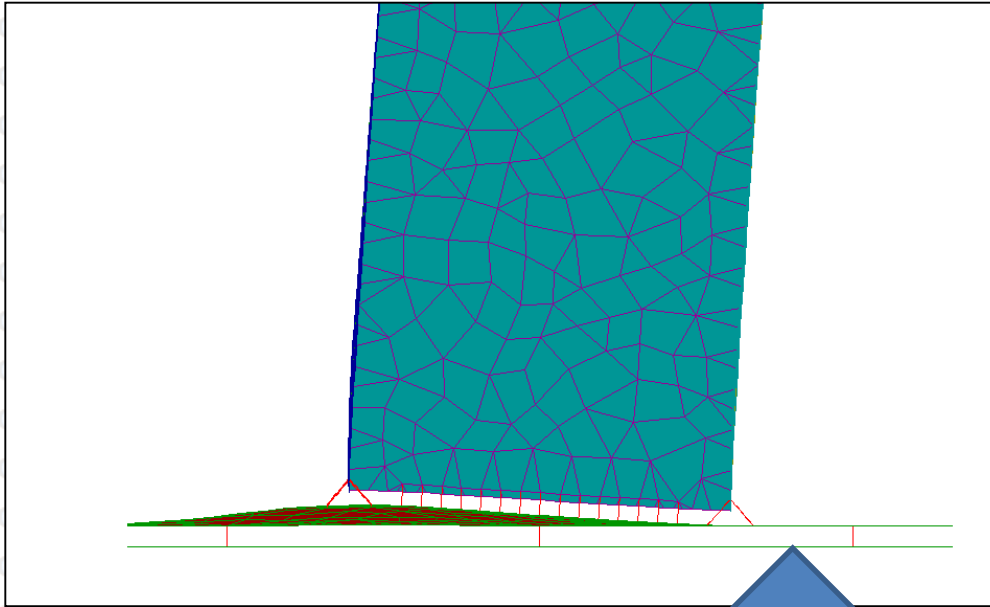

Scaled vectors

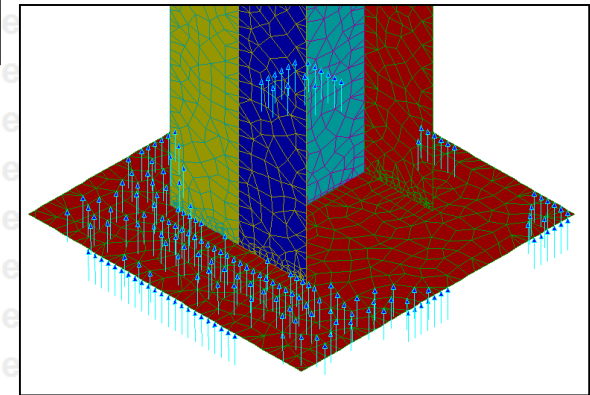

Unscaled vectors.

# Another CNL example...

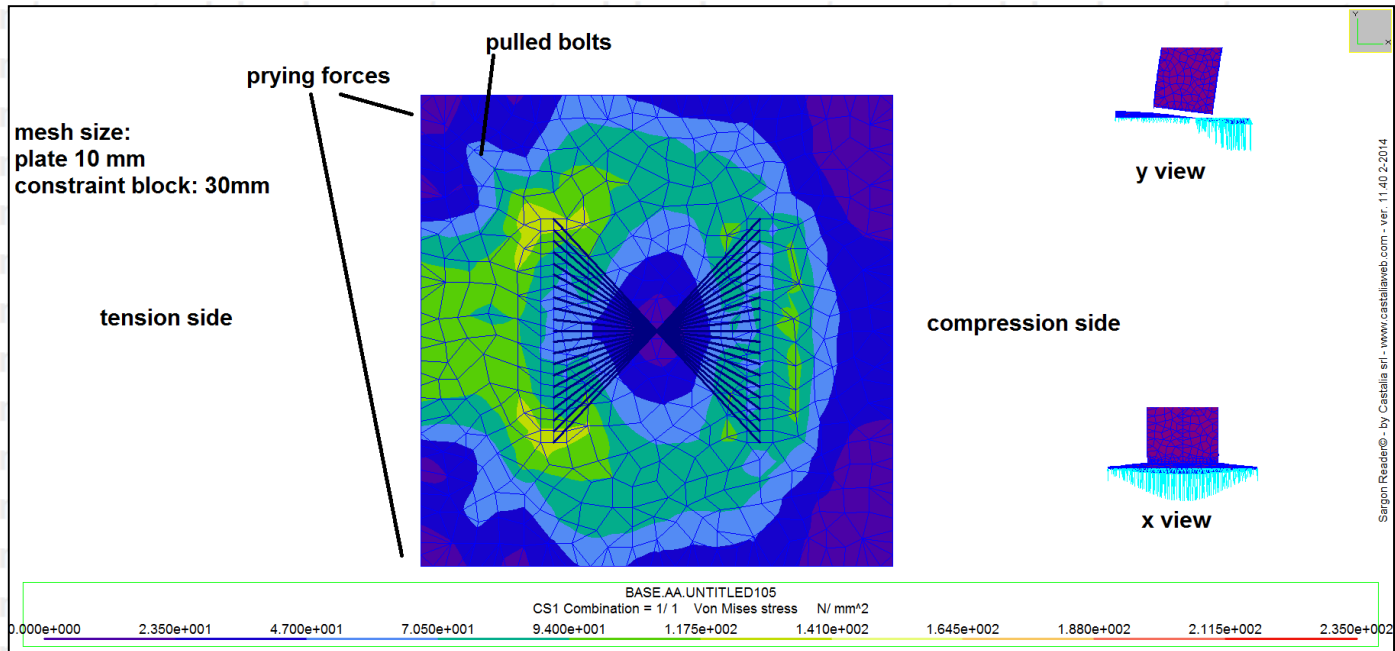

# Another CNL example...

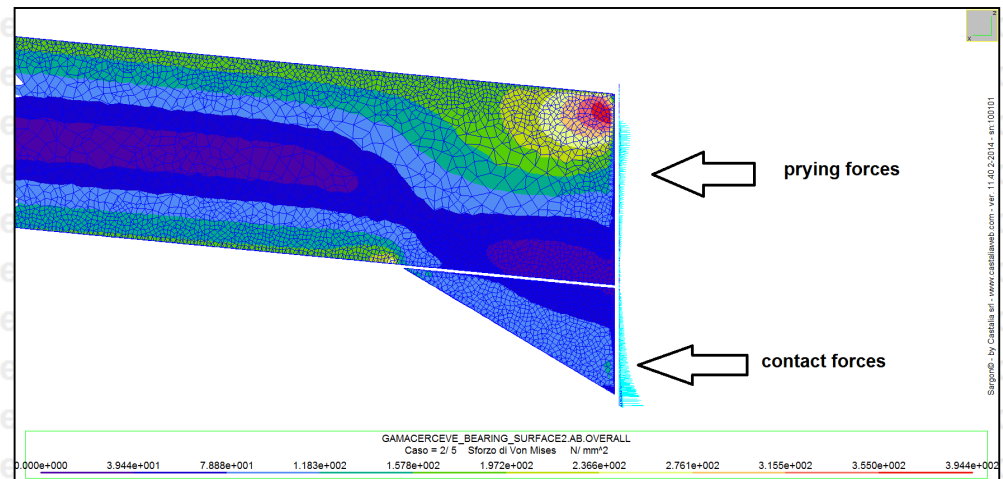
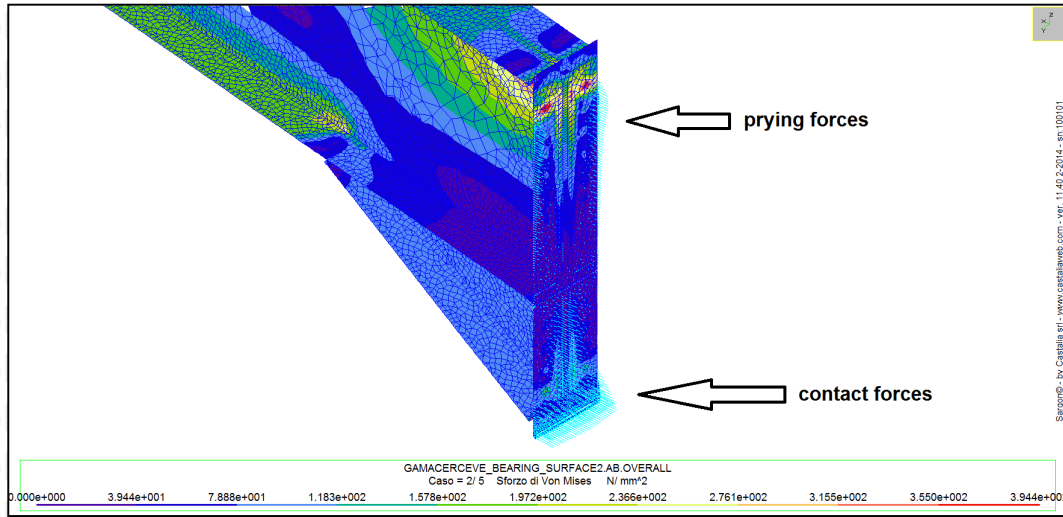

# Buckling checks (1)

- Eigenvalue analysis: critical multipliers can be found.
- Geometrically non linear analysis, convergence must be reached. More sophisticated, especially needed if there are plastic regions.
- The analysis can be run for SSFEM.
- Otherwise standard simple rules may also be used when applicable.

stable

unstable

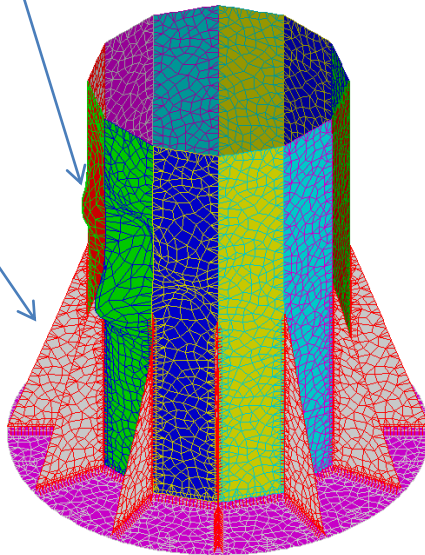

Combi= 7 Mode= 1 Alpha,crit = 3.246e+000

Buckling analysis results

Critical load multipliers for each combination

Combination =	Mode =	Alpha, crit =
1	1	20.3023
1	2	1.662e+002
1	3	2.098e+002
1	4	2.207e+002
1	5	2.269e+002
1	6	2.369e+002
1	7	2.554e+002
1	8	2.631e+002
1	9	2.906e+002
1	10	2.947e+002
2	1	19.4655
2	2	59.9882
2	3	95.7884
2	4	1.146e+002
2	5	1.263e+002
2	6	1.346e+002
2	7	1.459e+002
2	8	1.568e+002
2	9	1.673e+002
2	10	1.750e+002
3	1	26.7244
3	2	80.3856
3	3	1.313e+002
3	4	1.573e+002

OK

# Buckling checks (2)

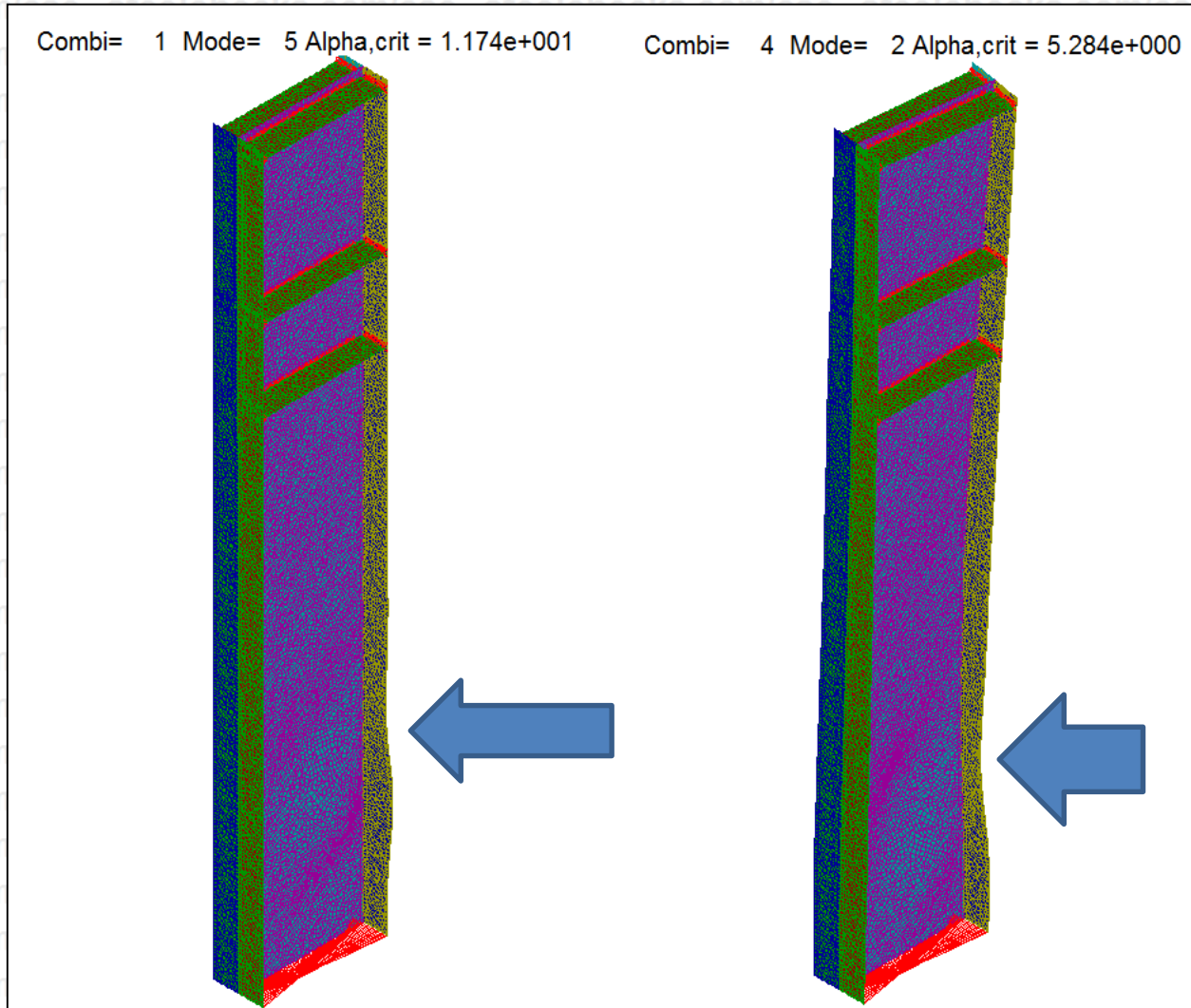

# SSFEM: more than 1 component (1)

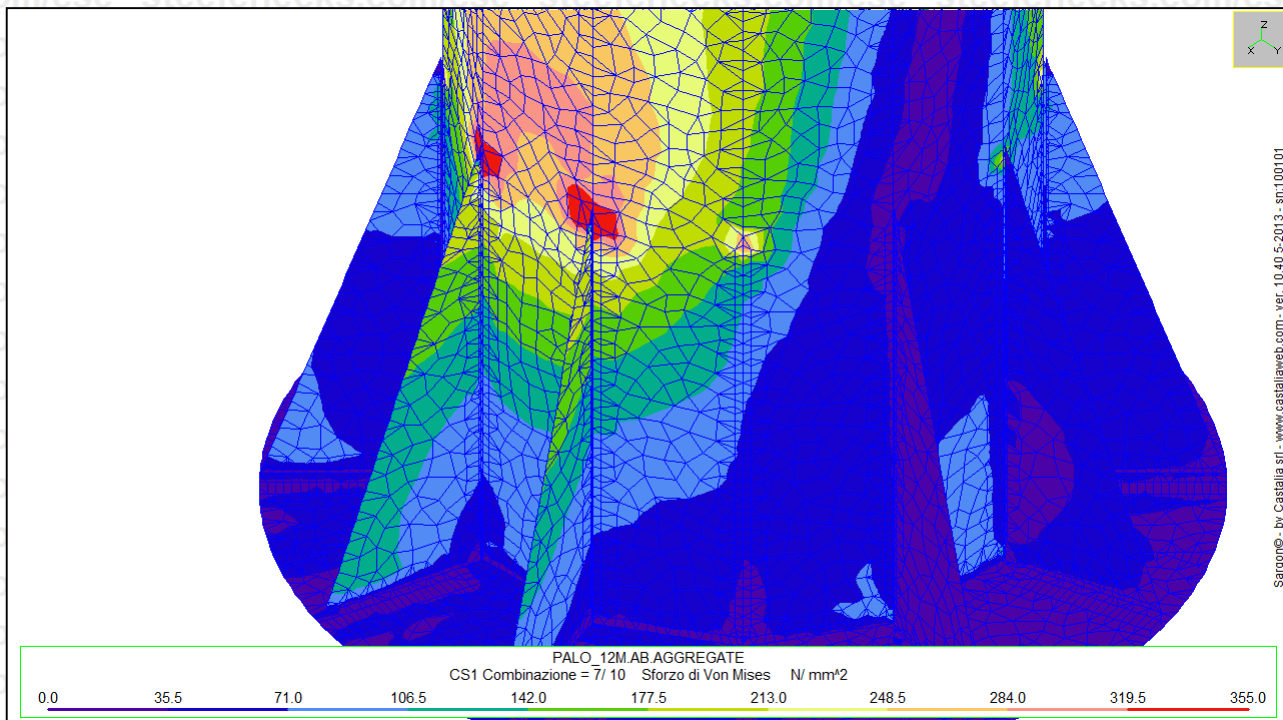

# SSFEM: more than 1 component (2)

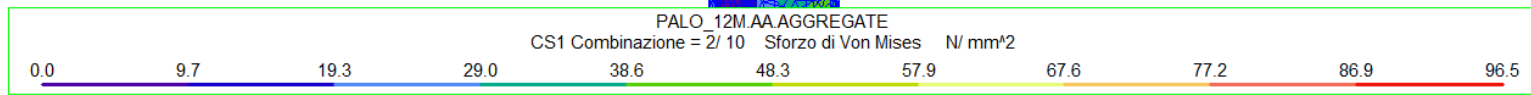
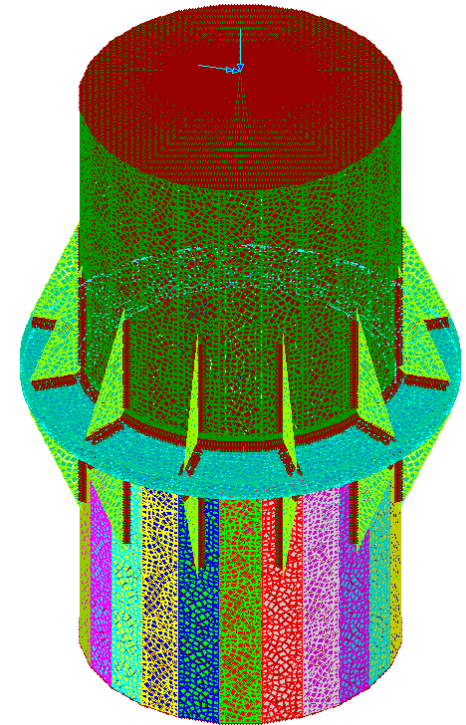
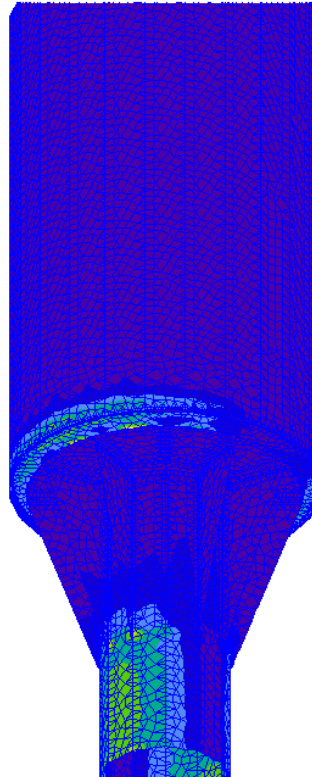
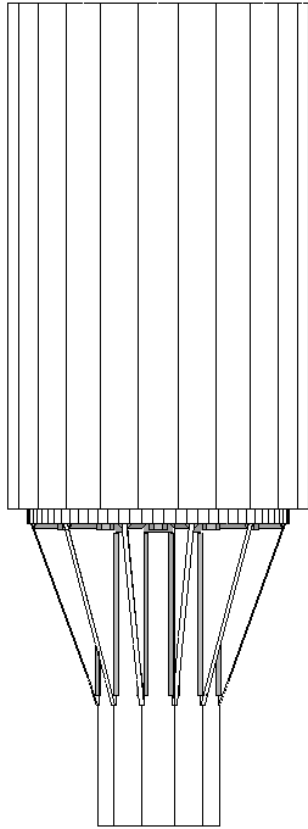

# SSFEM: more than 1 component (3)

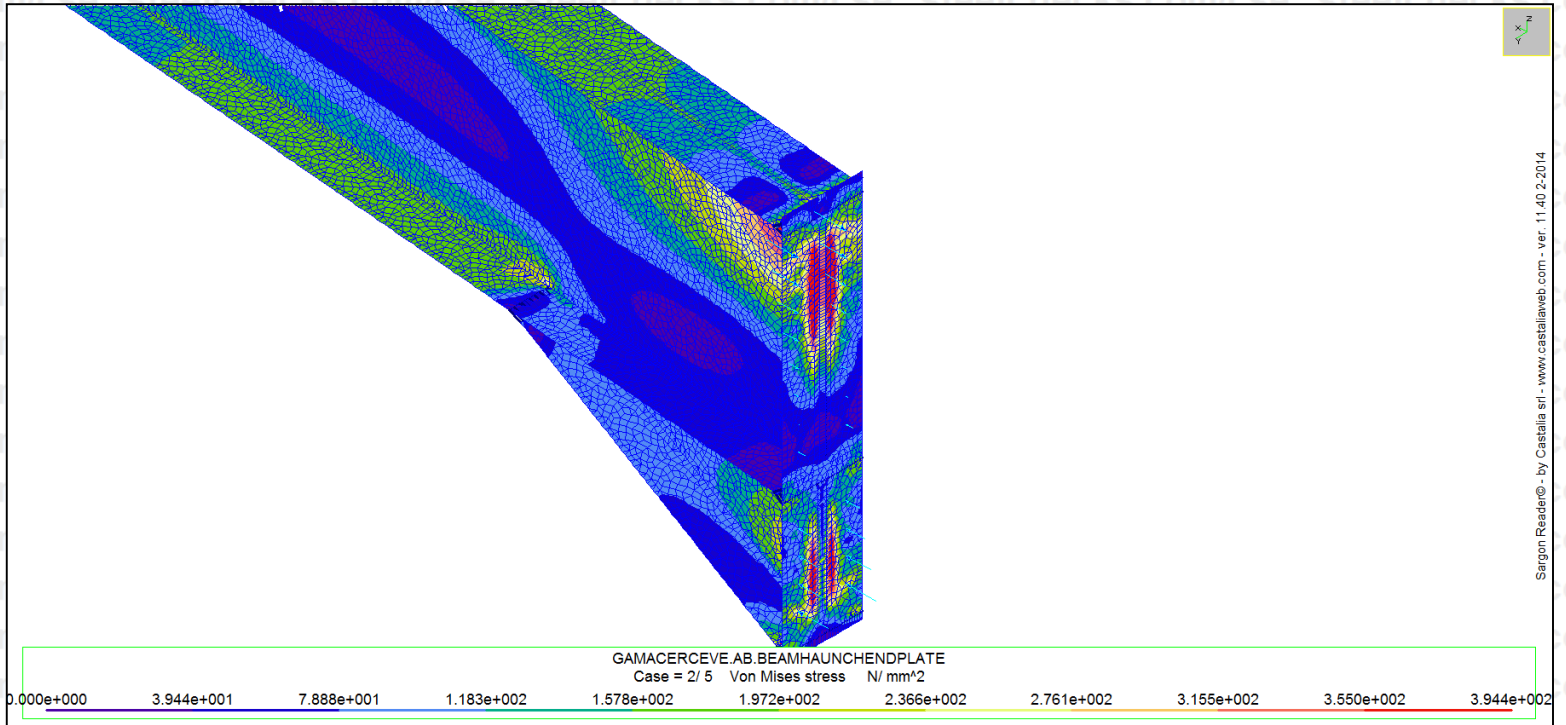

# SSFEM: more than 1 component (4)

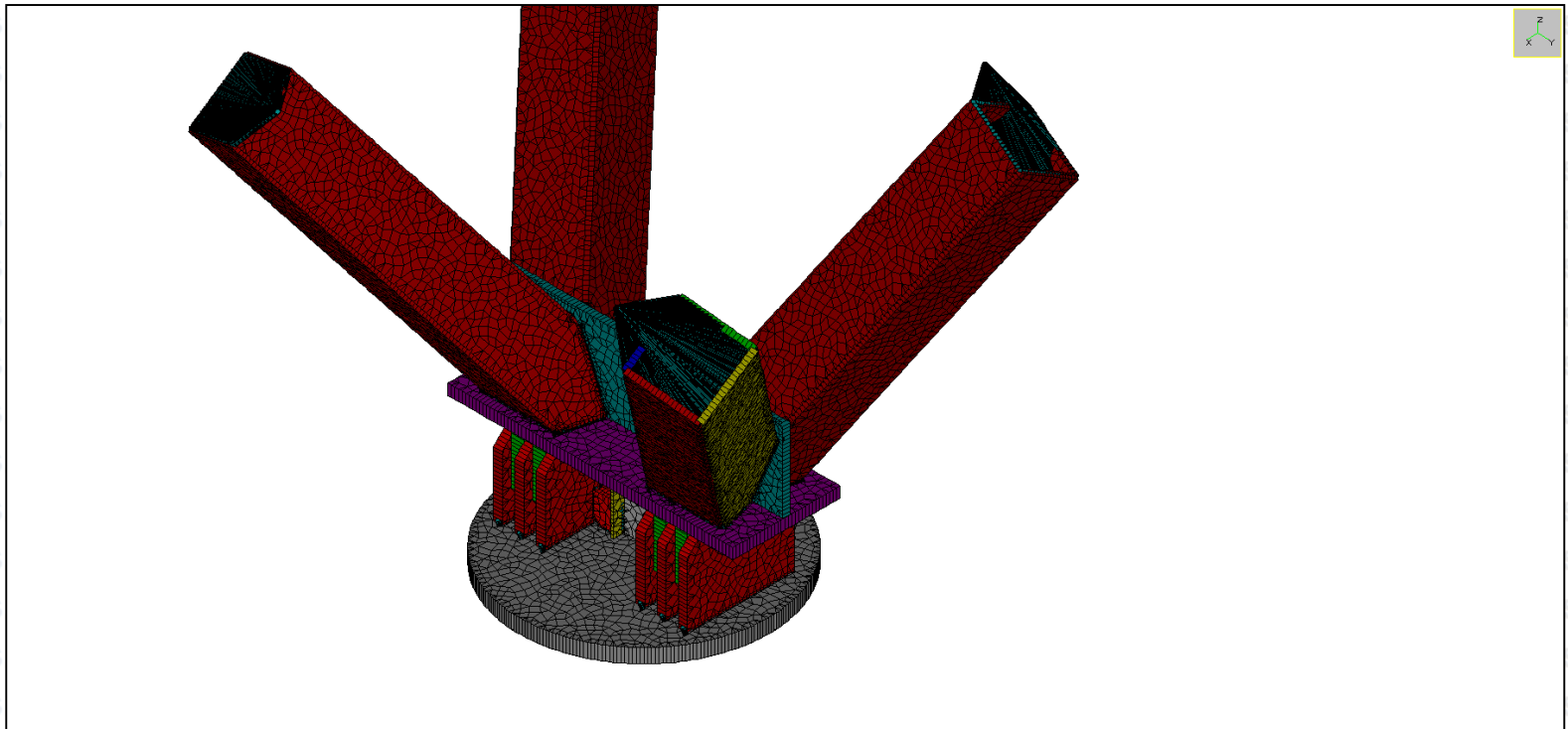
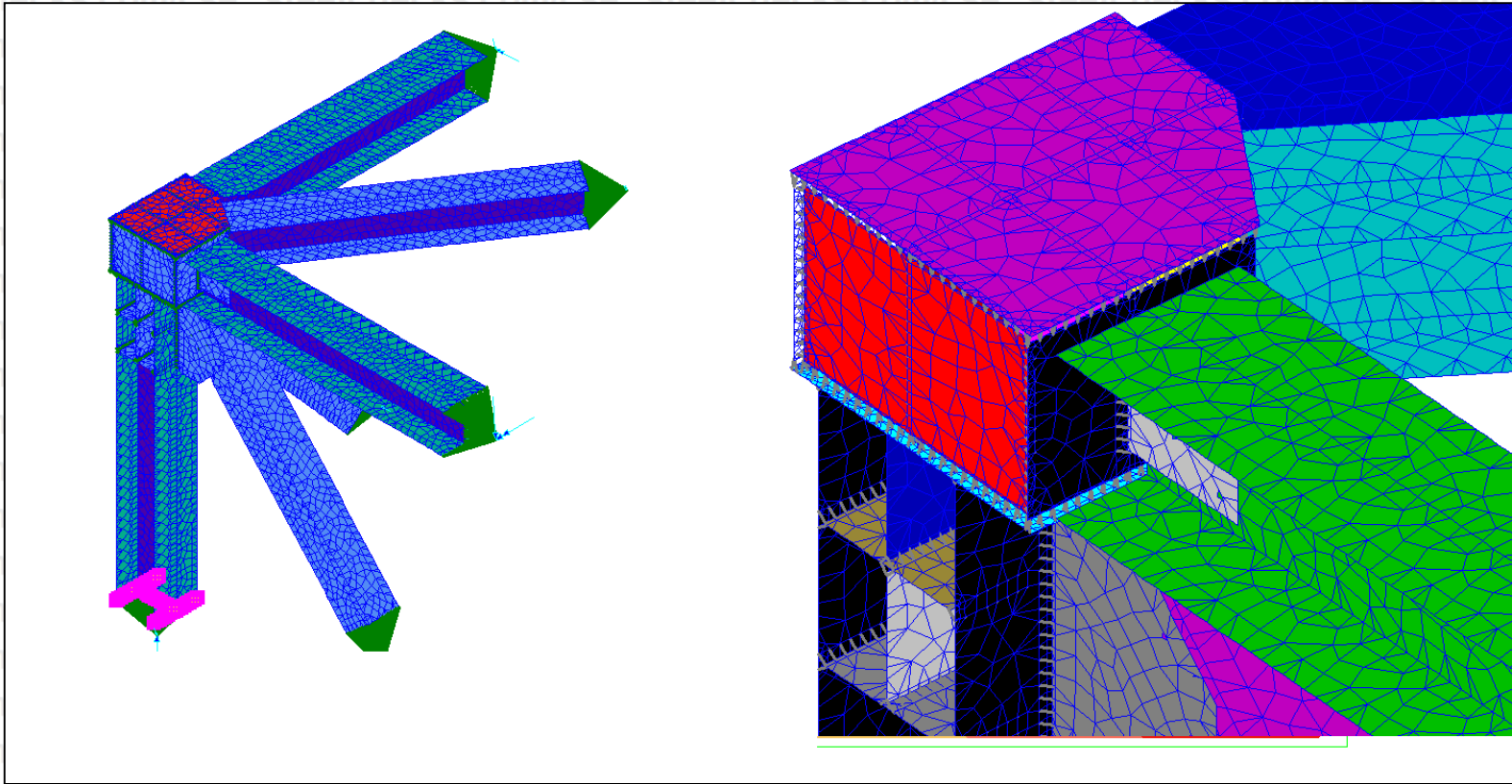

Plate-shell elements rendered as solids

# PFEM: some more



# Displacement control (1)

- IFEM is able to initially “test” the correctness of the design: if some component is not properly connected (e.g. bending moments over hinges), then the displacement levels are too high
- So the displacement check is one needed step to assure that the connections are properly designed

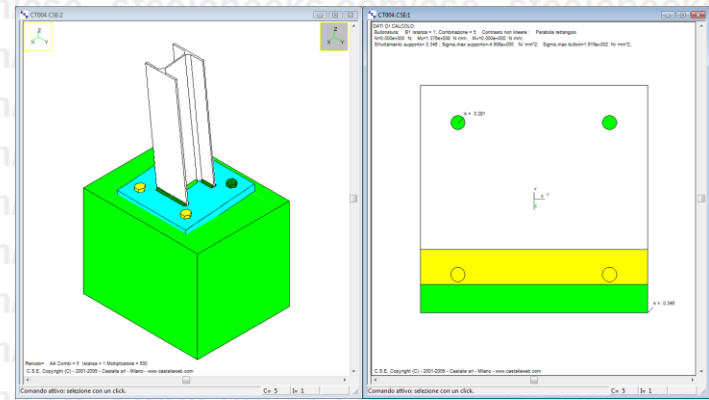
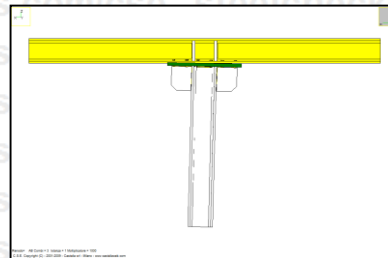
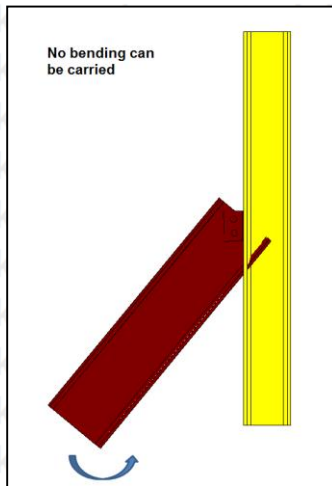
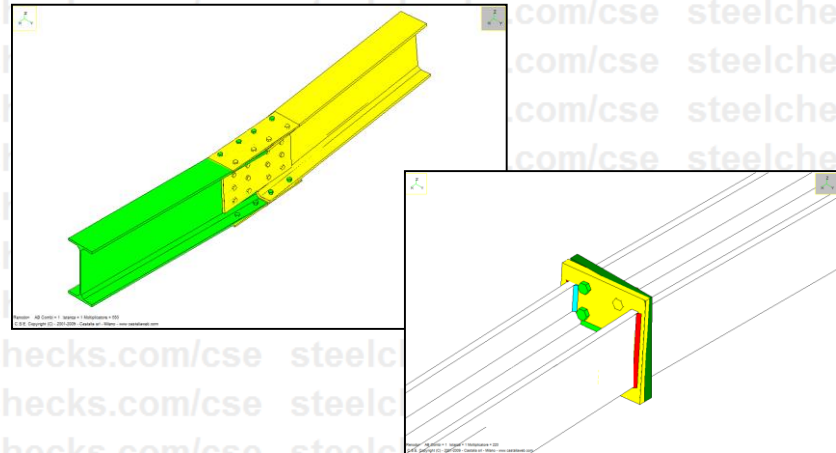

# Displacement control (2)

- More realistic displacement control may be got by SSFEM or PFEM.

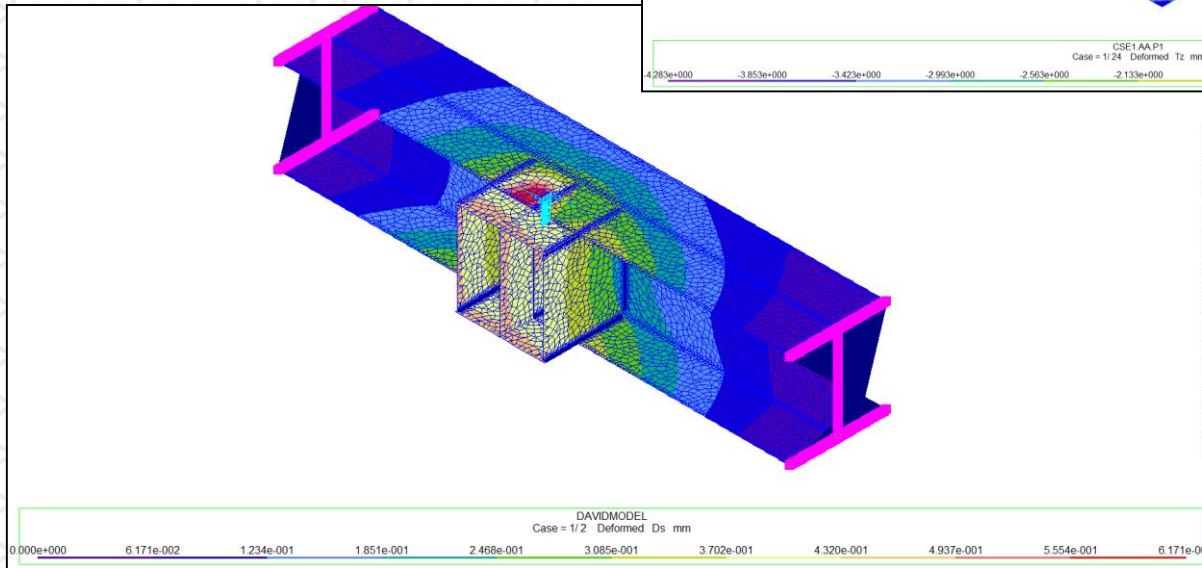
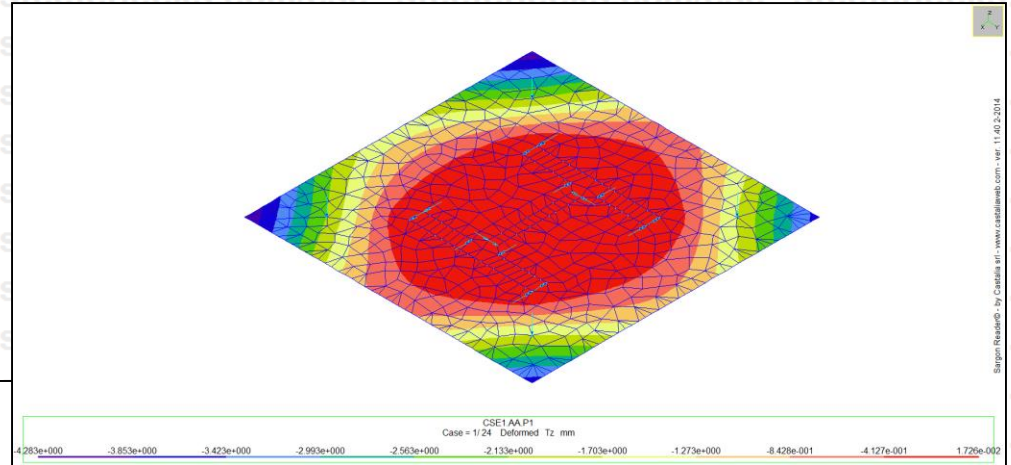

# SSFEM to compute STIFFNESSES

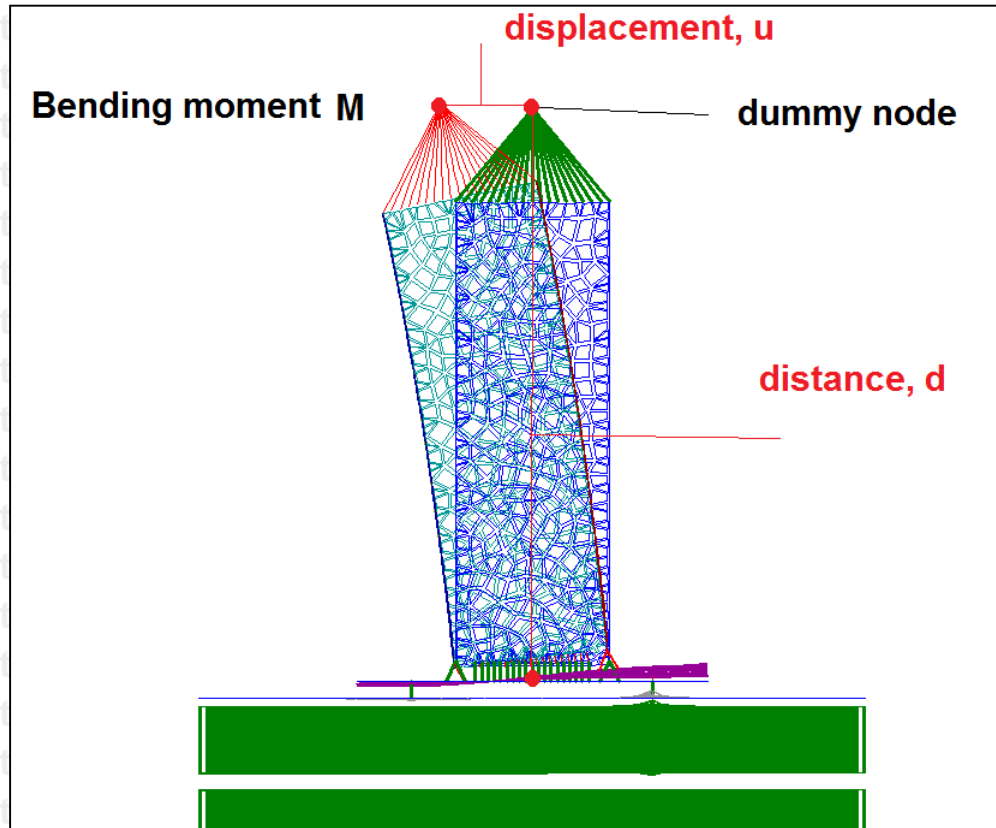

Quite easy...

# “User’s” and “standard” formulae

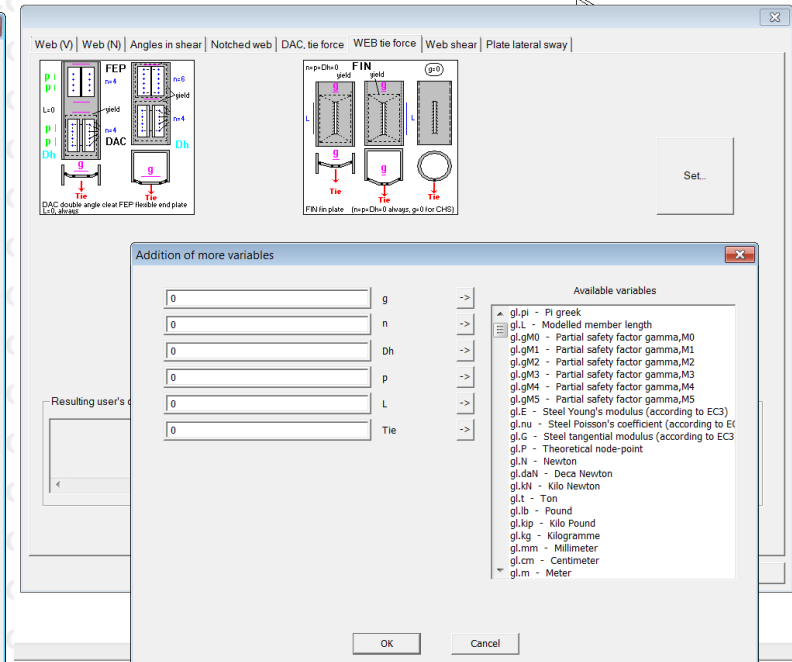
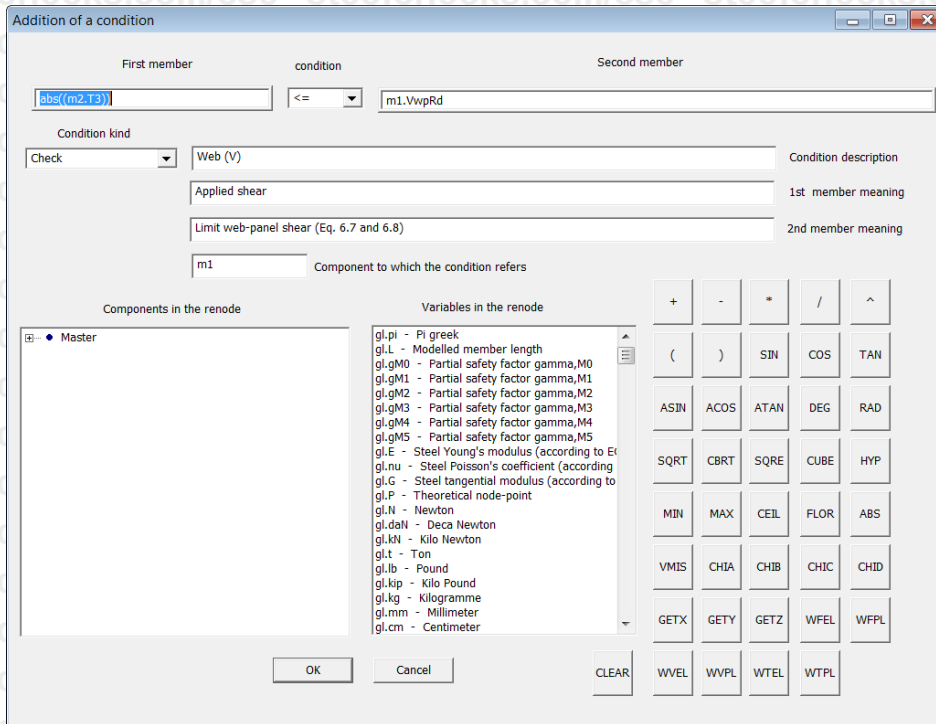

...”cooking recipes” approaches might still be used

# How manage all this?

- 1) Single component checking rules

Member

S275 Material Change... Modify... Add...

Member stump

1000 Length

Checks

Check net-sections  Use torsion

Fem modelling

Create FEM model  Use nonlinear computation

10 Borders and welds element size

30 Generic elements size (if 0 then free size)

19.8 Triangle minimum angle in degrees (default 19.8°)

0.1 Node distance tolerance (if dist < tol then the nodes are merged)

Search and mesh stiffeners when preparing fem model

OK Cancel

C.S.E.: Member check settings

171 Height (DY)

180 Length (DX)

15 Thickness (DZ)

P4 Name

S275 Material Change... Modify... Add...

Checks

Simplified checks  Use torsion

Fem modelling

Create FEM model  Use nonlinear computation

10 Borders and welds element size

30 Generic elements size (if 0 then free size)

19.8 Triangle minimum angle in degrees (default 19.8°)

0.1 Node distance tolerance (if dist < tol then the nodes are merged)

It is a stiffener

Search and mesh stiffeners when preparing fem model

OK Cancel

C.S.E.: component (plate) check settings

- 2) General checking rules (also single components SSFEM)

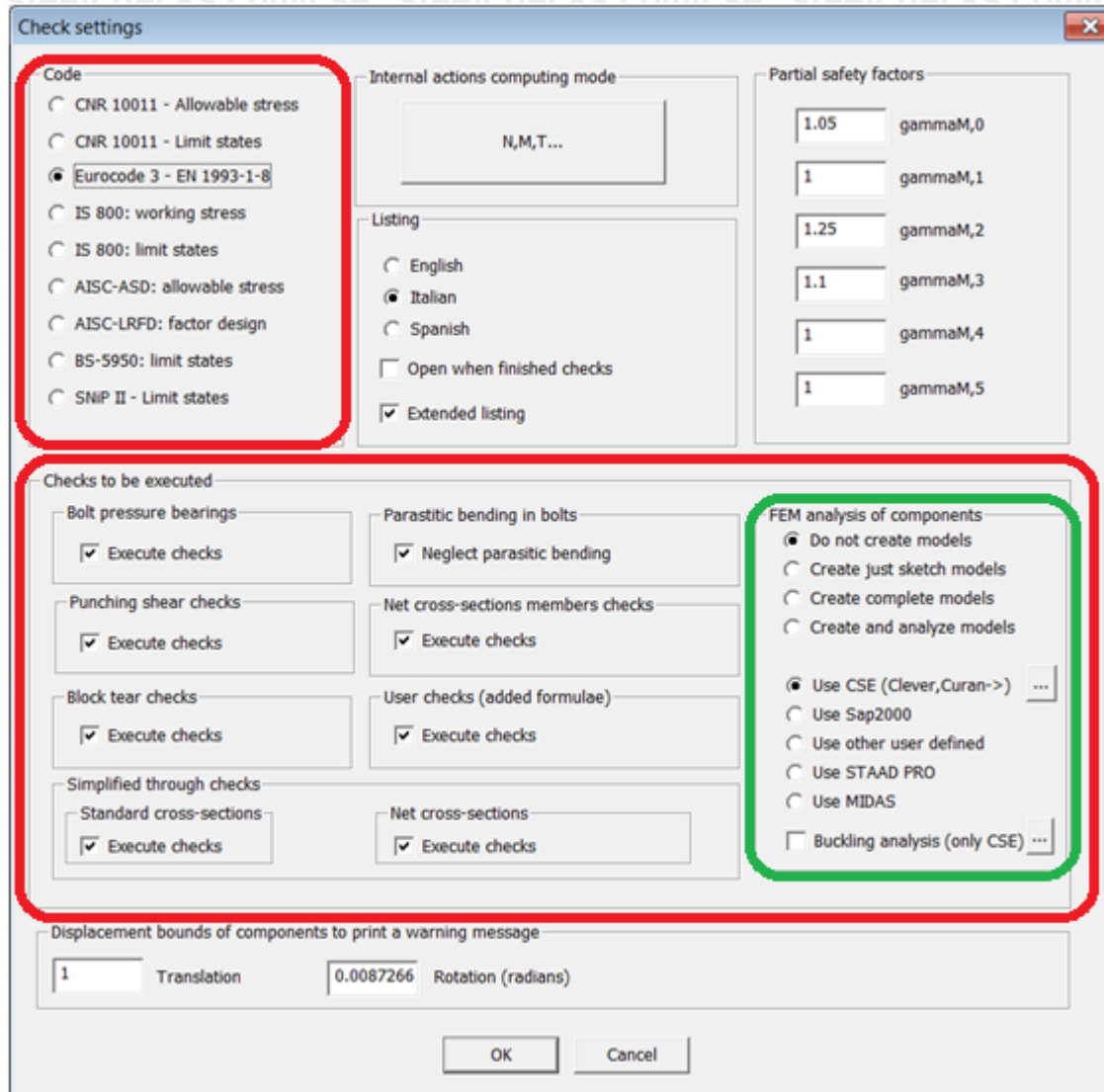

C.S.E.: check settings

# 3) PFEM and multiple SSFEM

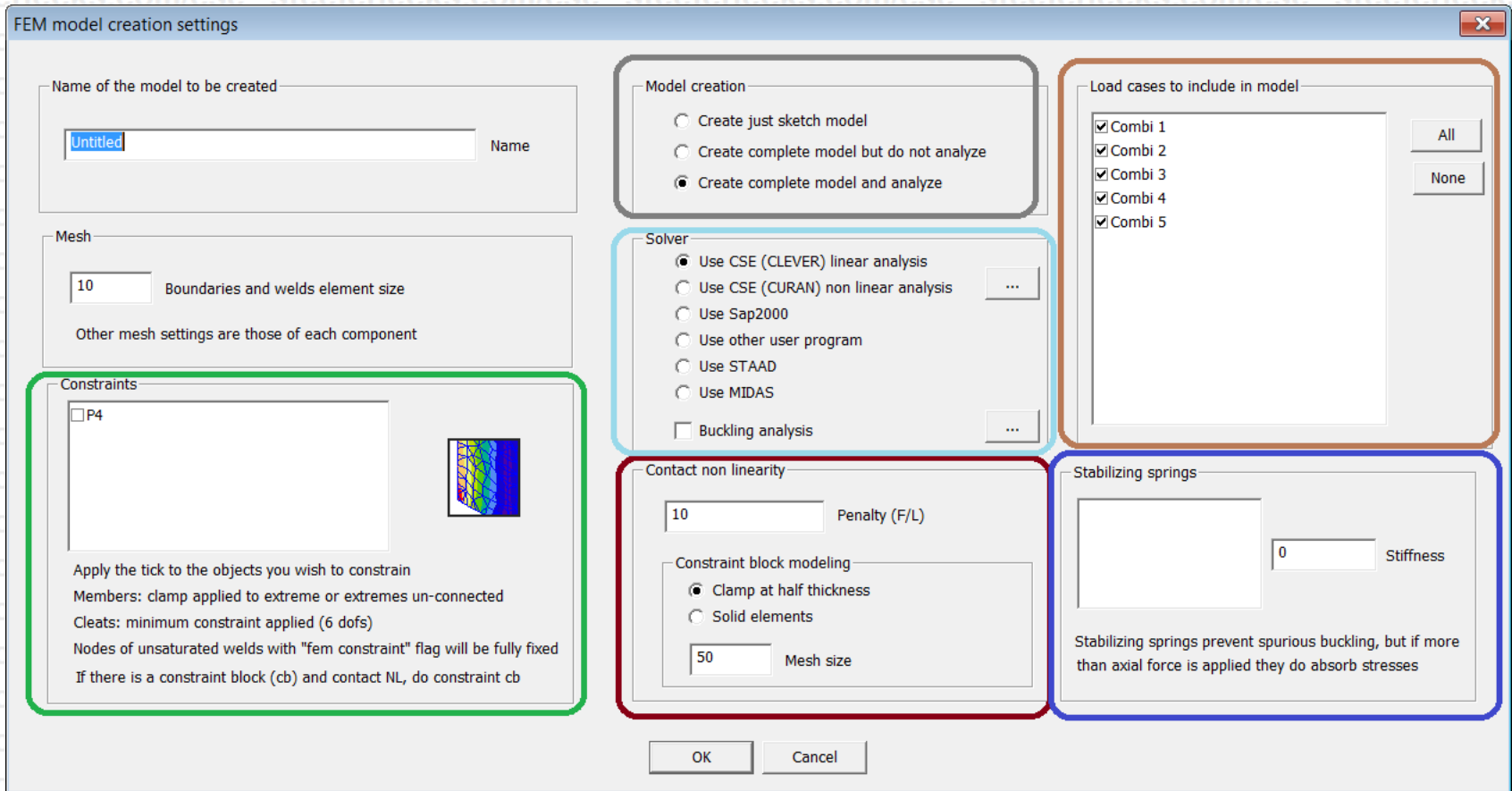

C.S.E.: FEM model of a set of components, settings

# A case history (1): no BS for BL

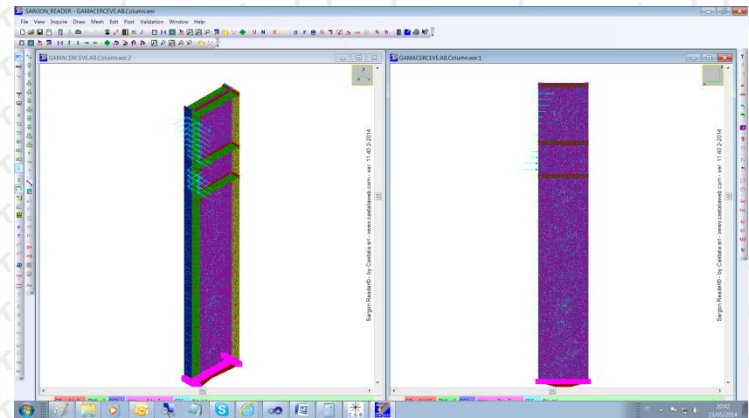
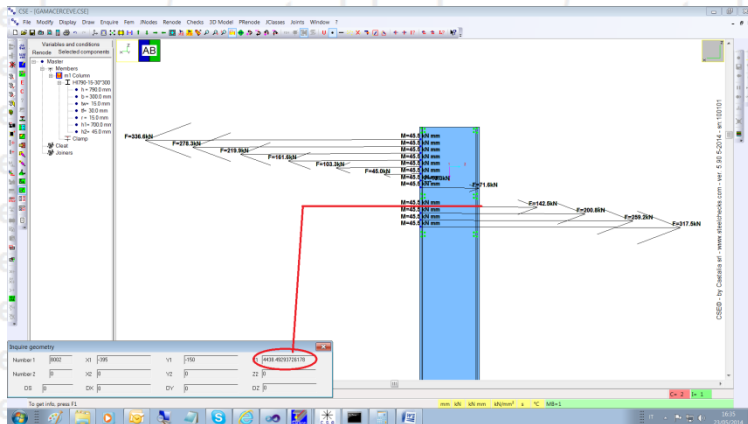
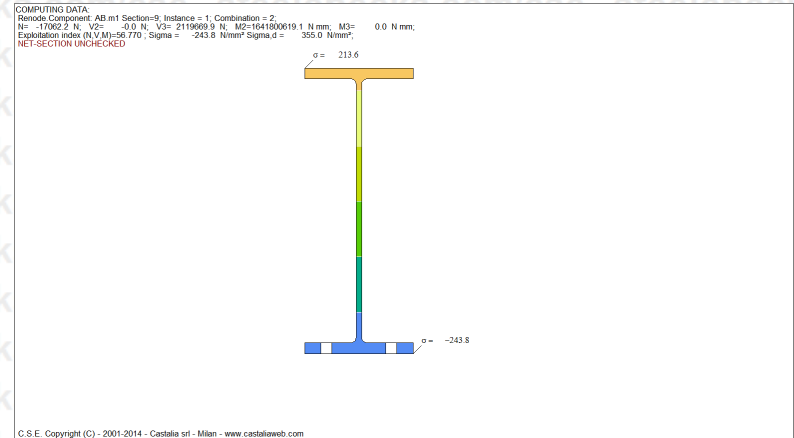
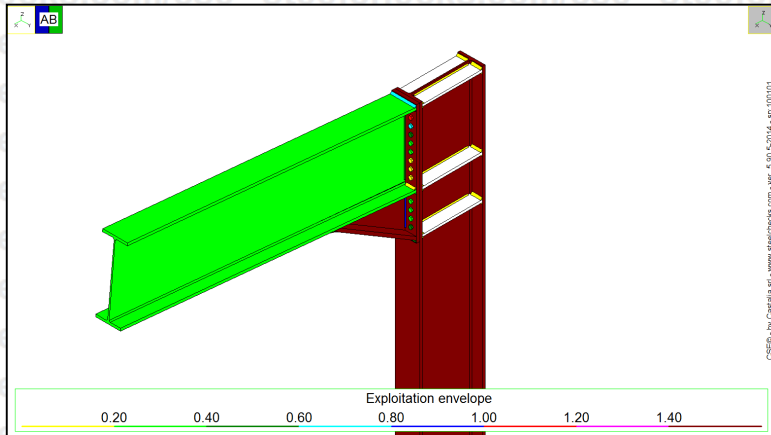

SSFEM:m1

# A case history (1): no BS

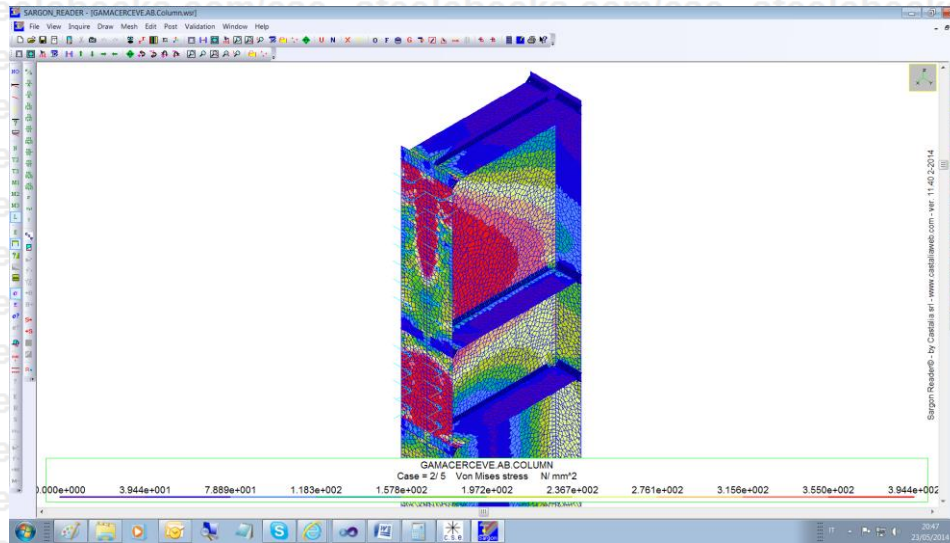

The SSFEM confirmed results  
of net cross-sections

Not using BS is allowed by  
Safe theorem but it is  
usually not convenient.

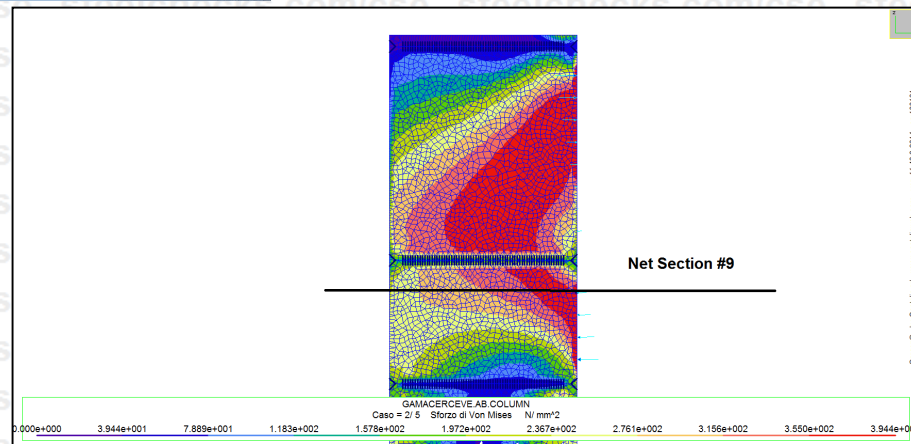

# A case history (1): no BS

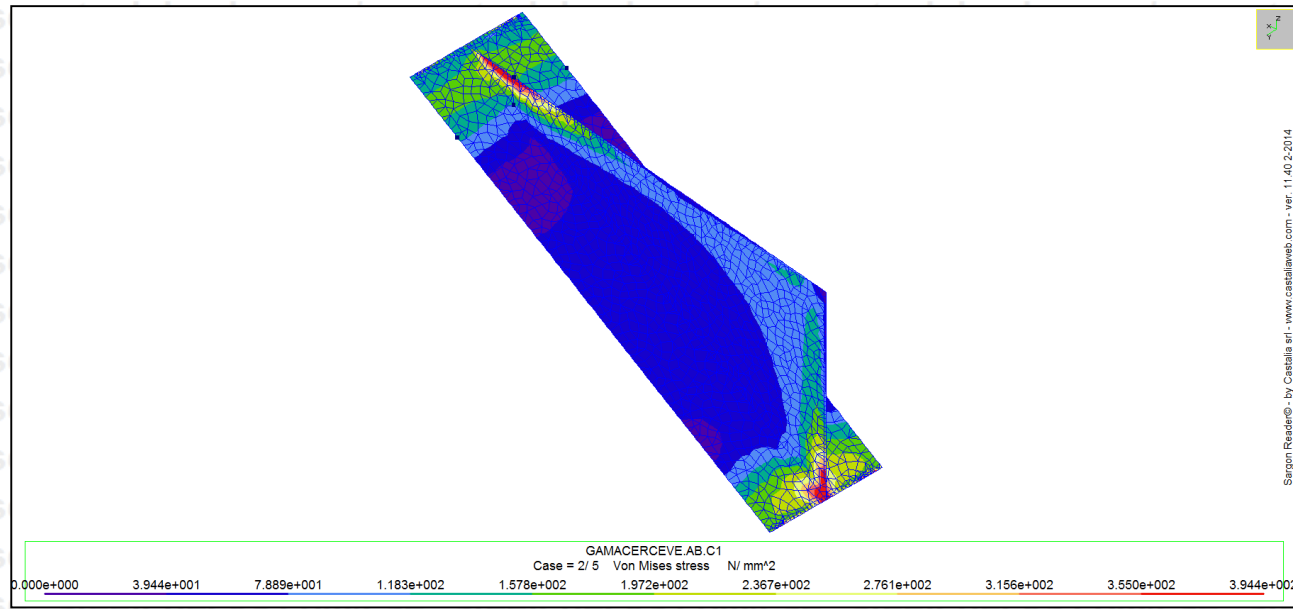

Also the haunch was not in an ideal condition

# A case history (2): BS

How define  $f_{jd}$ ?

$$f_{jd} \cdot \frac{c^2}{2} = f_y \frac{t^2}{6}$$

$$f_{jd} \cdot \frac{c^2}{2} = f_y \frac{t^2}{4}$$

Definition of c



Span c

plate thickness

fy (yield stress)

fjd (bearing surface design stress)

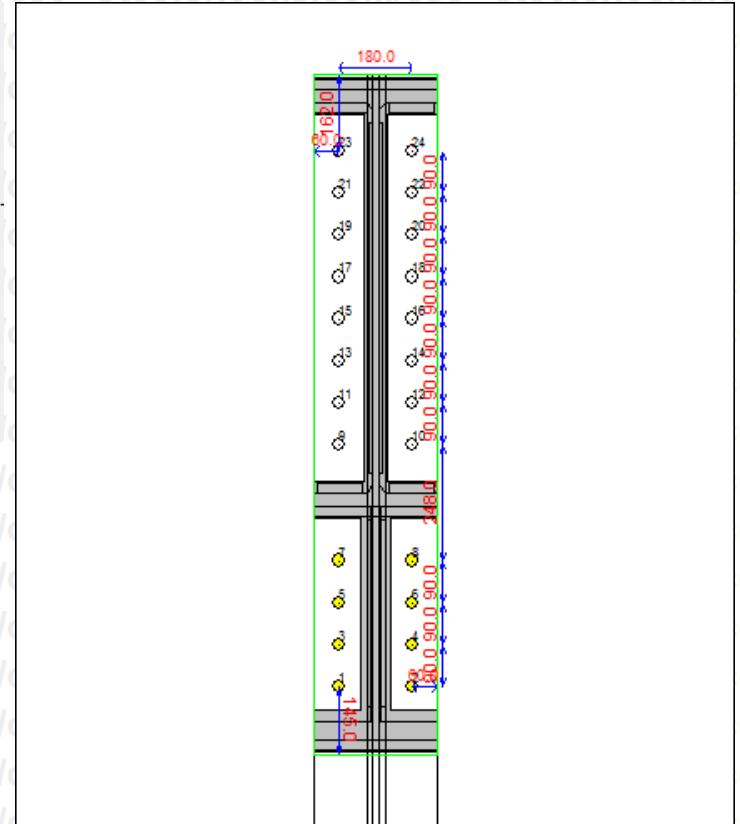

Linear strain field

1BL or 2 BL?

Bearing surface is intersected with  
plate borders

Now contact pressures do help to  
carry the loads

# A case history (2): BS

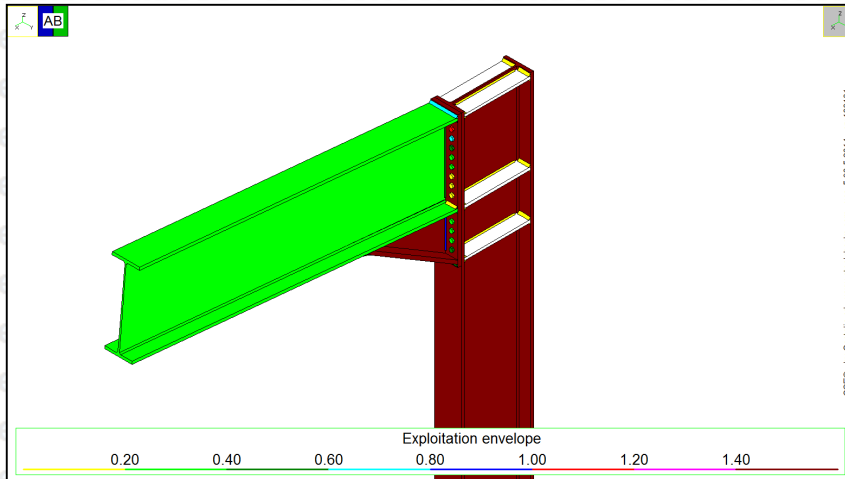

Simplified checks without BS

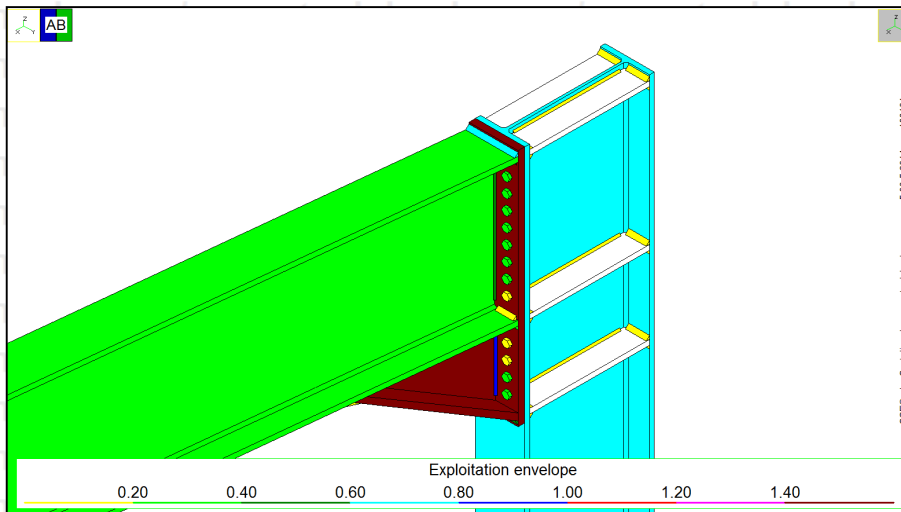

Simplified checks with BS:

- higher internal lever arm;
- Better spreading of pressures & forces
- But still problems in end plate & haunch: let's use SSFEM

# A case history (2): BS

COMPUTING DATA:  
 Bolt layout: B1 Instance = 1; Combination = 2; Linear elastic bearing (no tension) - dPNA = 713.475 mm aPNA= -0.0° maxdist,C,PNA=23.8946 mm  
 N= 279689.5 N; Mu=1843369550.8 N mm; Mv= -0.0 N mm;  
 Bearing exploitation= 0.005 ; Sigma,max bearing= -539.1 N/mm<sup>2</sup>; Sigma,max bolts= 284.5 N/mm<sup>2</sup>; Tau,max bolts= 1.9 N/mm<sup>2</sup>;

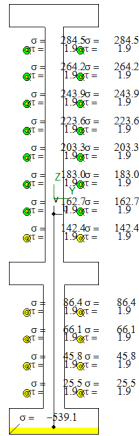

C.S.E. Copyright (C) - 2001-2014 - Castalia srl - Milan - www.castaliaweb.com

COMPUTING DATA:  
 Bolt layout: B1 Instance = 1; Combination = 2; Linear elastic bearing (no tension) - dPNA = 495.063 mm aPNA= -0.0° maxdist,C,PNA=242.307 mm  
 N= 279689.5 N; Mu=1843369550.8 N mm; Mv= -0.0 N mm;  
 Bearing exploitation= 0.001 ; Sigma,max bearing= -74.9 N/mm<sup>2</sup>; Sigma,max bolts= 322.2 N/mm<sup>2</sup>; Tau,max bolts= 1.9 N/mm<sup>2</sup>;

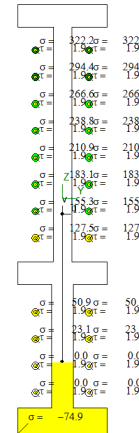

C.S.E. Copyright (C) - 2001-2014 - Castalia srl - Milan - www.castaliaweb.com

The effect of bearing surface “constitutive law”.



Increasing stiffness

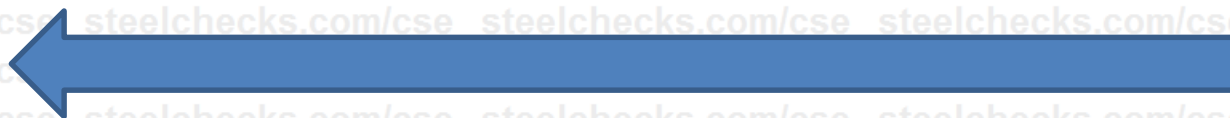
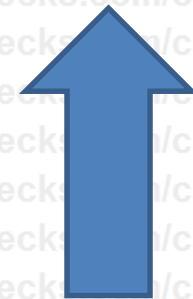

# A case history (2): BS, SSFEM

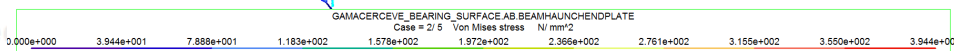
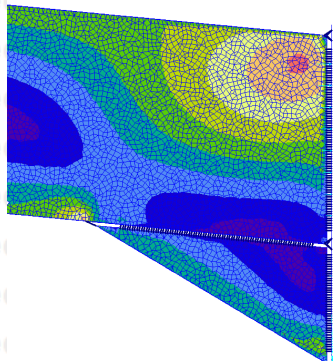
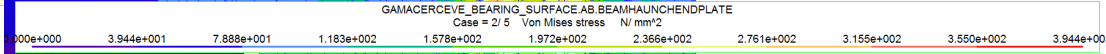
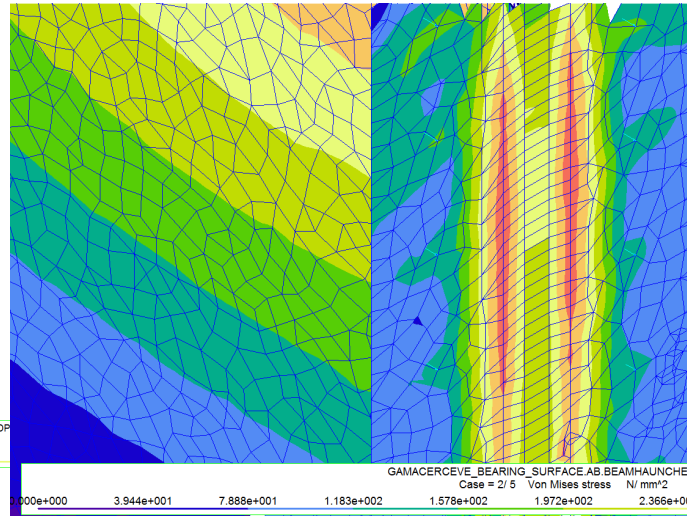
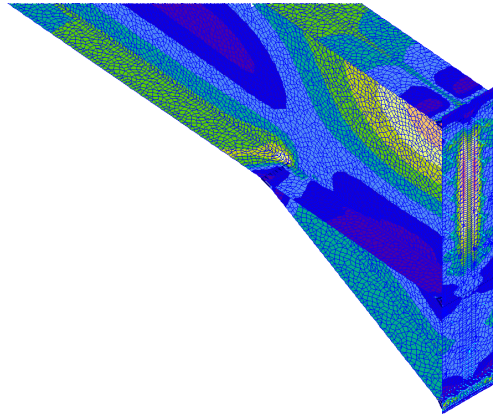

Linear strain field;  
SSFEM: near the limit

# A case history (3): BS, CNL, PFEM

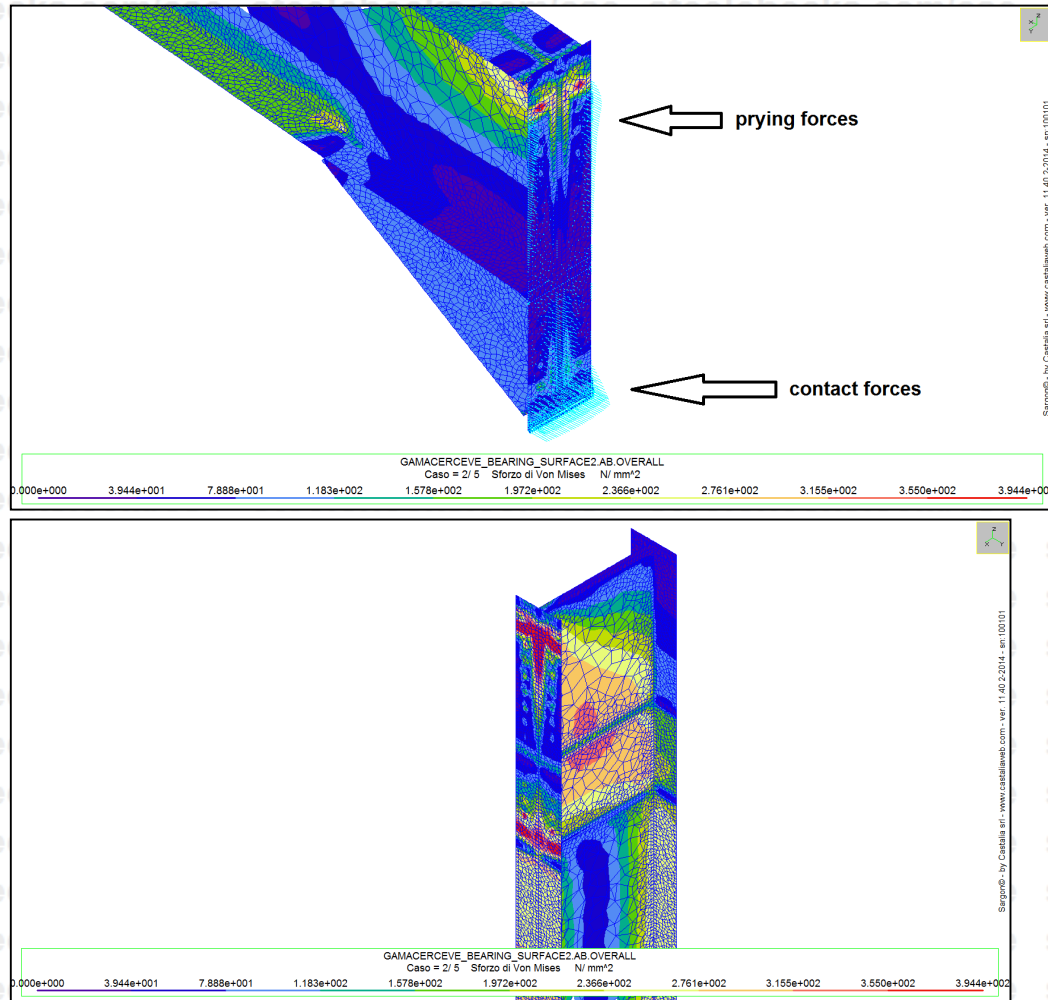

- Different force distribution
- Different VM map
- We cannot be sure it's ok
- -> Try CNL+MNL(EPP)

# A case history (4): BS, CNL+MNL(EPP), PFEM

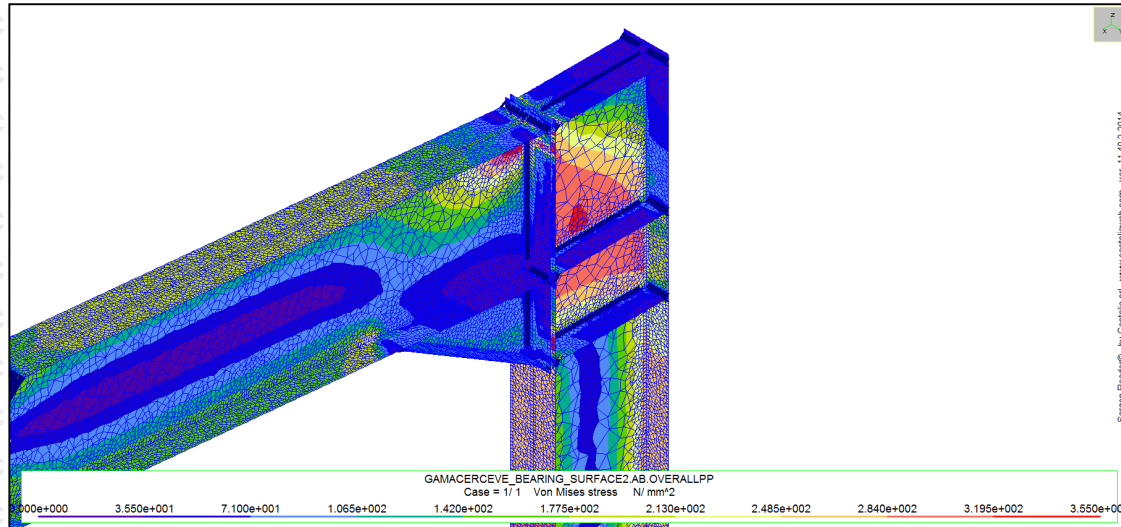

- Spreading of plasticity clearly visible.
- **It changes Vm map.**
- Maximum VM = 355 Mpa (as expected)
- We can assume the connection pass the check, however:

- 1) We did not modify the design and “payed” with greatest computational effort in order to “prove” the design is correct;
- 2) There is not “one solution” but a set (Safe Theorem)
- 3) Are there “standard connections” out there?

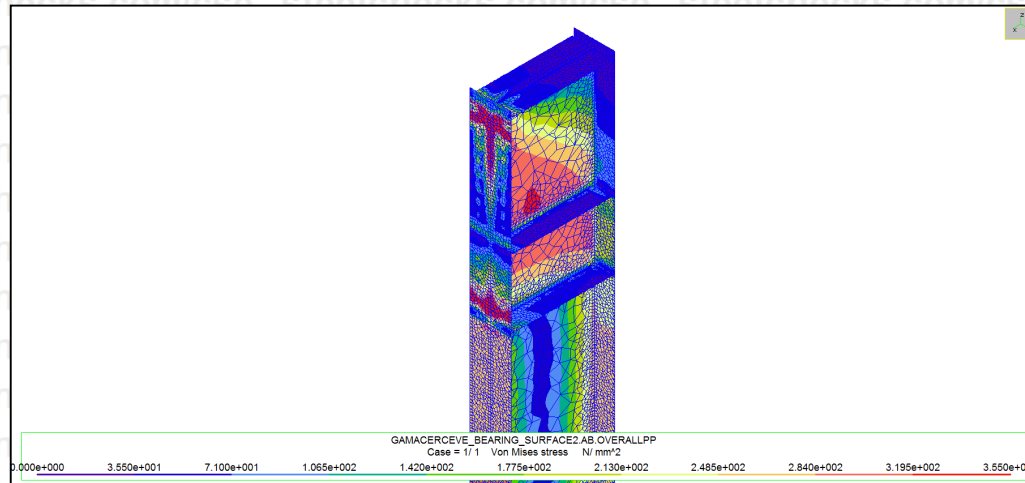

# Summing up:

1. FEM is a general and flexible tool to study connection
2. FEM is able to deepen analysis that are otherwise condemned to be done with often oversimplifying assumptions.
3. FEM can be and has been fully automated in C.S.E..
4. FEM can be used as a “coarse” mean of evaluation.
5. **Hybrid approaches are available which save a lot of computational time (C.S.E.).**
6. Computational times are now very short for most of the tasks.
7. Specific highly nonlinear problems, many combinations, may require some c.t.
8. The new paradigm will gradually replace simplified methods as first tool-to-be-used, as already happened in 3D fem modeling of structures.

THANK YOU

# Contact Info

Castalia srl

Via Pinturicchio, 24

20133 Milan – Italy

+39 (2) 26681083

+39 (2) 26681876

[info@castaliaweb.com](mailto:info@castaliaweb.com)

[www.steelchecks.com](http://www.steelchecks.com)

[www.castaliaweb.com](http://www.castaliaweb.com)

Ing. Paolo Rugarli - Castalia srl - Milan - Italy

- [www.castaliaweb.com](http://www.castaliaweb.com) -

[www.steelchecks.com](http://www.steelchecks.com)